

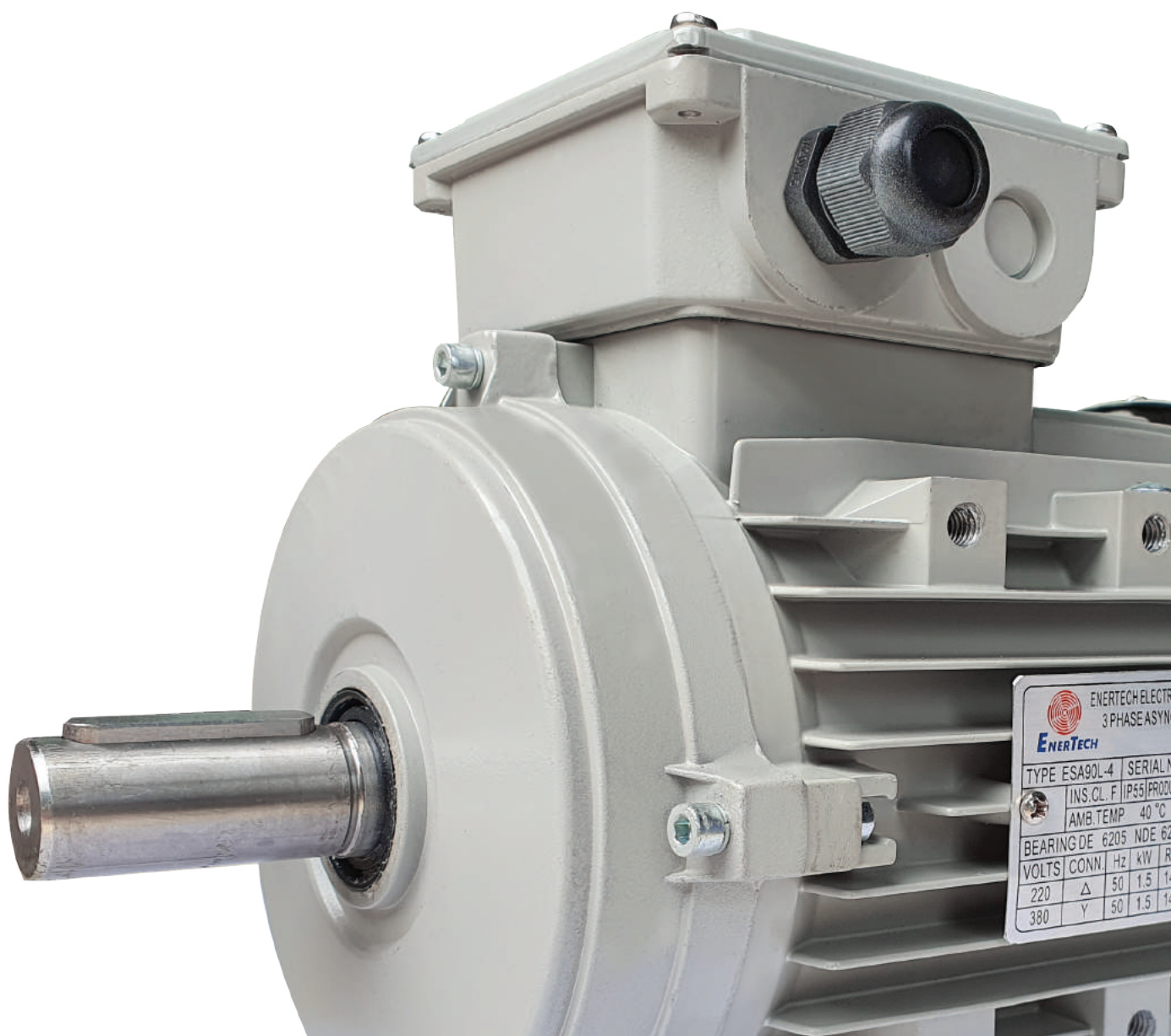

ALUMINIUM SERIES MOTORS

ENERTECHMOTORS.COM.AU





ENERTECHMOTORS.COM.AU

ESA-ESS-ESD

Aluminium Series Motors



Table of **CONTENTS**

NO.01

INTRODUCTION 4

NO.02

GENERAL SPECIFICATION 5

NO.03

STANDARD AND REGULATION 8

NO.04

ELECTRICAL DESIGN 11

NO.05

DESIGN FEATURES 16

NO.06

EFFICIENCY CLASSIFICATION 18

NO.07

ESA SERIES 19

PERFORMANCE DATA 20

2 Poles 20

IE1 4 Poles 21

6 Poles 22

8 Poles 23

IE2 24

IE3 25

DIMENSION 26

NO.08

ESS SERIES 28

PERFORMANCE DATA 29

DIMENSION 30

NO.09

ESD SERIES 32

PERFORMANCE DATA 33

DIMENSION 34

NO.10

BEARING & OIL SEAL 36

INTRODUCTION

Aluminium motors are suitable for driving various kinds of machines or equipments. The output ratings are from 0.18kW to 500kW. The frame sizes are from 80 to 400.





The Aluminium motors have cast iron stator frames, endshields and terminal boxes. The feet integrally cast into the stator frame.

The location of the terminal box in standard design is on the top, on the right or on the left are possible. The position of the entry opening can be adjusted to suit the existing connection facilities by turning through 90°.

All motors comply with the requirements of European CE marking.

All motors are designed for high efficiency and low temperature giving a long economical service life.

Motors from frame size 63 to 160 with aluminium stator frames, terminal boxes and cast iron endshields are also available.

 <p>ISET S.r.l.</p> <p><small>Sede Legale e Uffici: Via Donatori di sangue, 9 - 46024 Moglia (MN) Tel. e fax +39 (0)376 598963 iset@iset-italia.com www.iset-italia.eu</small></p> <p><small>Cap. soc. i.v. € 10.200,00 Cod. Fisc. e P.IVA 02 332 750 369 Reg. Imprese 02 332 750 369 REA MN 0221096</small></p>	
<p>CERTIFICATE OF COMPLIANCE</p> <p>Certificado de Conformidade - Сертификат соответствия - Konformitätserklärung</p>	
<p>1) APPLICANT: Enertech Electric Motors (Australia) 5 Kintyre Court, Greenvale 3059, Victoria, Australia.</p>	<p>2) CERTIFICATE NO.: IT041253ET170135 TEST REPORT(S) NO.: SCC(17)-70012A-01-LVD SCC(17)-70012A-01-EMC CEPREI (Sichuan) Laboratory.</p>
<p>3) WITH REFERENCE TO EC DIRECTIVE APPLIED: Low Voltage Directive 2014/35/EU Electromagnetic Compatibility 2014/30/EU</p> <p>HARMONIZED STANDARDS APPLIED: EN 60034-1:2010+AC:2010; EN 61000-6-1:2007 EN 61000-6-3:2007/A1:2011/AC:2012 EN 61000-3-2:2014; EN 61000-3-3:2013</p>	<p>4) CERTIFICATION ISET MARK:</p> 
<p>5) PRODUCT CHARACTERISTICS: ESA Series Three-phase Asynchronous Motor</p> <p>MODEL(S): See the following annex I</p>	
<p>REMARK: This verification has been carried out on voluntary application of the manufacturer based only on the documents prepared and provided by the manufacturer itself. The product(s) satisfies the requirements of the Certification Mark of ISET according to the ISET regulations. The manufacturer is responsible to maintain the internal production control to ensure the compliance of the products. ISET declines any liability with reference to any other non-compliance of documents, product or test report that have been submitted to evaluation. However, marking and EC declaration are duties of the manufacturer before putting into service of its product(s) on market. The manufacturer is liable to take all the necessary actions required by the applicable directives & producers.</p>	
<p>6) DATE OF ISSUE: 19/01/2017</p>	<p>DATE OF EXPIRE: 18/01/2022</p>
<p>CERTIFICATION MANAGER: </p> 	



General Specification

Cooling and ventilation _____

The standard cooling method is Totally Enclosed Fan-Cooled (TEFC) in accordance with code IC411 of IEC 60034-6. Standard motors in sizes 80-315 are equipped with radial-flow plastic fans. Standard motors in size 355 are equipped with radial-flow aluminium fans.

Voltage and frequency _____

Standard voltage is 400V/50Hz but can be manufactured for any single voltage in the range 200-600V at a frequency 50 or 60 Hz. The motors will operate satisfactorily with voltage variations of $\pm 5\%$ from the rated voltage.

Noise _____

The permitted noise levels of electrical machines are fixed in IEC60034 - 9 (EN60034-9). The noise level of ESA motors is well below these limit value. For details, please refer to the performance data tables.

Quality assurance _____

Stringent quality procedures are observed from first design to finished products in accordance with ISO9001 documented quality systems. Our factories have been assessed to meet these requirements, a further assurance that only the highest possible standards of quality are accepted.

Enclosure _____

The standard degree of protection is IP55. The IP55 enclosure means complete hoseproof and dustproof protection. A higher degree of protection is available.

Connection _____

Direct on line starting can be used on all frame sizes. Motors up to and including 3kW are star connected and cannot be started with Star/Delt started. Motors 4kW and above can be started with Star/Delta started.

Vibration _____

Standard motors are designed for vibration class N (normal). Vibration class R (reduced) and vibration class S (special) are available on request.



Against solar radiation

High solar radiation will result in undue temperature rise. In these circumstances, motors should be screened from solar radiation by placement of adequate sunshades which do not inhibit air flow.

Degree of protection

Standard levels of enclosure protection for all Aluminium frame sizes for both motor and the terminal box is IP55, with IP56, IP65 and IP66 available on request. Enclosure designations comply with IEC60529 or AS60529. The enclosure protection required will depend upon the environmental and operational conditions within which the motor is to operate.

IP standards explanation

I P	5	5
	1	2

International protection rating prefix
(IEC 60034 - 5)

First numeral

First characteristic numeral

Degree of protection of persons against approach to live parts or contact with live or moving parts (other than smooth rotating shafts and the like) inside the enclosure, and degree of protection of equipment within the enclosure against the ingress of solid foreign bodies.

4. Protected against solid object greater than 1.0 mm: Wires or strips of thickness greater than 1.0 mm, solid objects exceeding 1.0 mm.
5. Dust protected: Ingress of dust is not totally prevented but it does not enter in sufficient quantity to interfere with satisfactory operation of the equipment.
6. Dust tight: No ingress of dust.

Second numeral

Second characteristic numeral

4. Protected against splashing water: Water splashed against the enclosure from any direction shall have no harmful effect.
5. Protected against water jets: Water projected by a nozzle against the enclosure from any direction shall have no harmful effect.
6. Protected against heavy seas: Water from heavy seas or water projected in powerful jets (larger nozzle and higher pressure than second numeral 5) shall not enter the enclosure in harmful quantities.

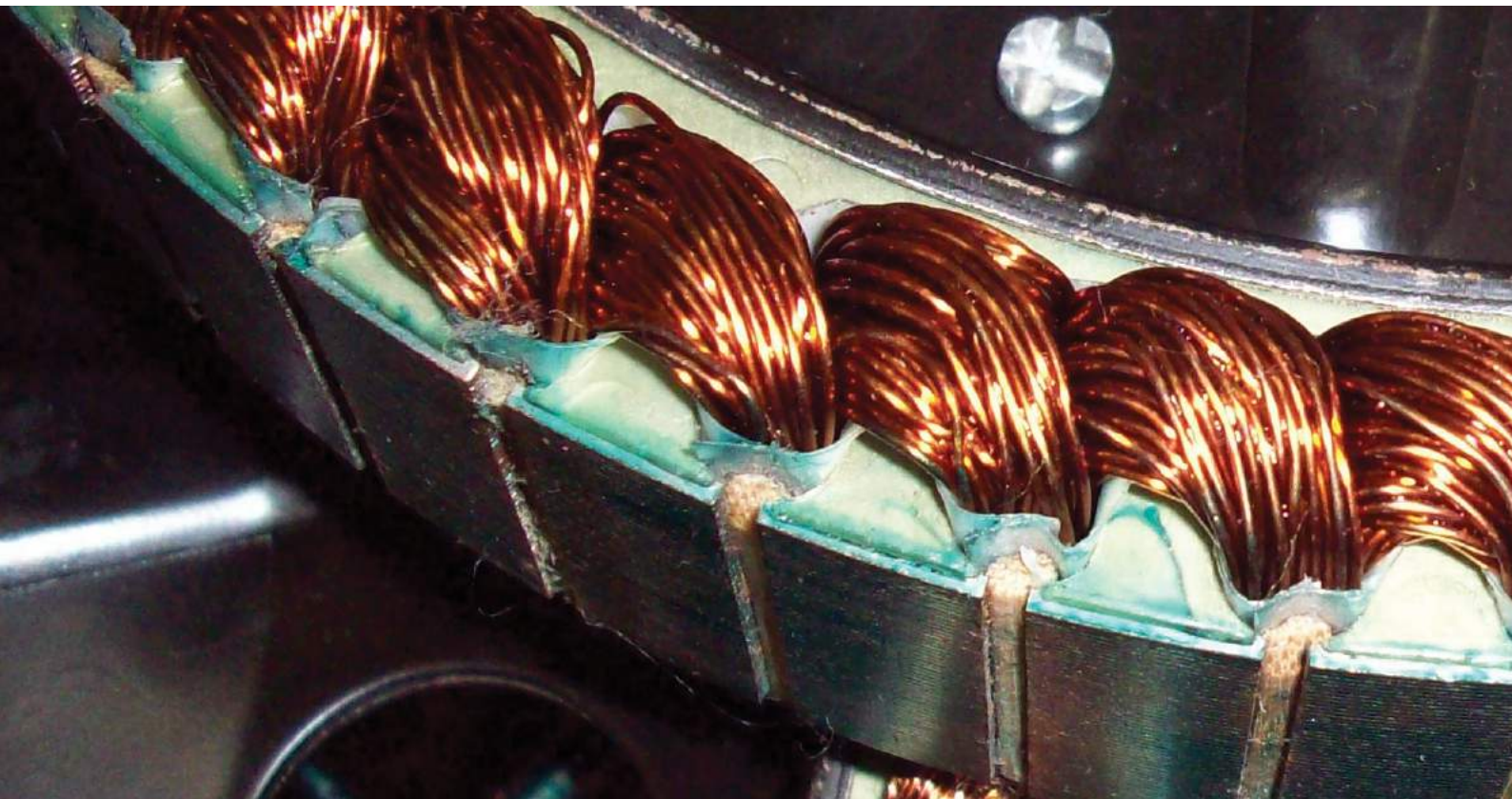

Shaft

ESA motors have standard shaft extension lengths which provided with standard key, drilled and tapped hole. Non standard shaft extensions are available upon special order, with shaft design outlined on a detailed drawing. Shaft extension run out, concentricity and perpendicularity to face of standard flange mount motors, comply with normal grade tolerance as specified in IEC 60072-1 and AS1359. Precision grade tolerance is available upon special order.

Finish

Standard Aluminium motors color is RAL 9006. Other colors are also available. All castings and steel parts are provided with a prime coat of rust-resistant paint. The finishing coat of enamel paint is sufficient for normal conditions, however special paint systems can be provided to accommodate stringent requirements for motors in corrosive environments. Special coatings are needed to resist such substances as acid, salt water and extreme climatic conditions.

Electrical design

As standard, Aluminium motors have the following design and operating parameters. Performance data is based on this standard. Any deviation should be examined and performance values altered in accordance with the information provided in this section.

Three phase, 380-415V/50Hz, 440-480V/60Hz

Ambient cooling air temperature, 40°C

Altitude 1000m

Duty cycle S1 (continuous)

Rotation Clockwise viewed from drive end

Connection 230 volt Delta/400 volt Star (3kW and below)

400 volt Delta/690 volt Star (4kW and above)

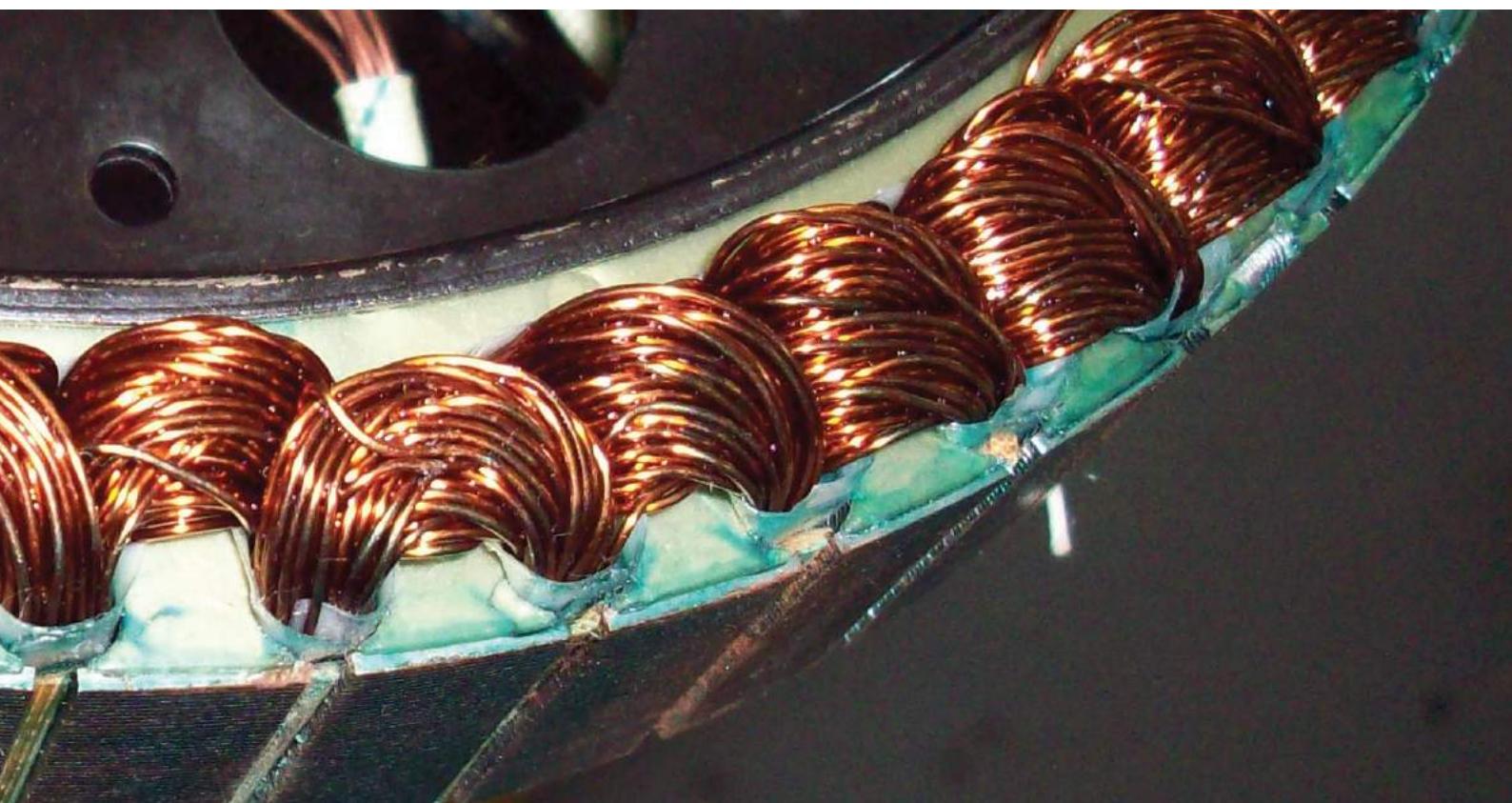

Standards and regulations

Aluminium motors are built to comply with the requirements of the following international standards and regulation:

1. International Electrotechnical Commission - IEC 60034 and IEC 60072.
2. British Standards - BS5000 and BS 4999.
3. Australian Standards - AS 1359.
4. The requirements of European CE marking. Low voltage Directive 73/23 (1973), modified by Directive 93/68 (1993) and the EMC-Directive 89/336. These Aluminium motors are designed to use with other machinery, and they should only be used if the complete machinery is in conformity with the provisions of the Directive of safety of machinery (89/93/EEC).
5. CEMEP agreement - All motors with standard rating include in this catalog comply with efficiency class IE1, IE2 & IE3 and bear the corresponding label on the rating plate. For efficiency data at 50%, 75% and full load, please refer to the performance data tables.

Standards	IEC	CENELEC	BS
General requirements for electrical machines	60034-1	EN 60034-1	4999-1 4999-69
Methods of determining losses and efficiency	60034-2	HD 53 2	4999-34
Degrees of protection	60034-5	EN60034-5	4999-20
Methods of cooling	60034-6	EN60034-6	4999-21
Mounting arrangements	60034-7	EN60034-7	4999-22
Terminal markings and direction of rotation	60034-8	HD 53 8S4	4999-3
Noise limits	60034-9	EN60034-9	4999-51
Starting performance	60034-12	EN60034-12	4999-112
Mechanical vibration	60034-14	EN60034-14	4999-50
Standard voltages	60038	HD 472 S1	---
Dimensions and output ratings	60072	---	---
Mounting dimensions and relationship framesizes-output ratings	60072	HD 231	4999-10 51-110
Shaft dimensions	60072	HD 231	4999-10
Classification of environmental conditions	600721-2-1	---	---
Insulation material	60085	---	---

*The Aluminium motor range corresponds to the new international standard IEC 60034-30



Standards mounting arrangements

Foot mounting



Large flange

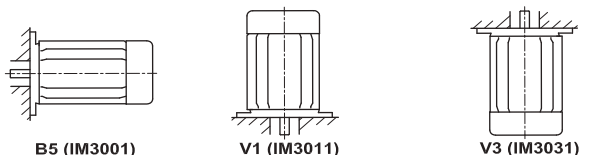

Large flange and feet

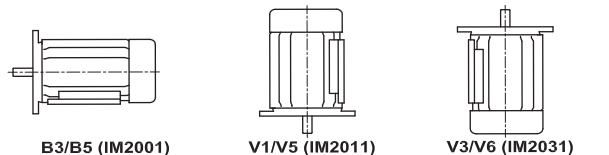

Small flange (face)

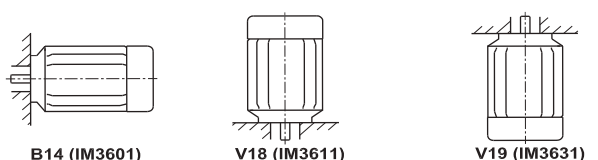

Small flange (face) and feet

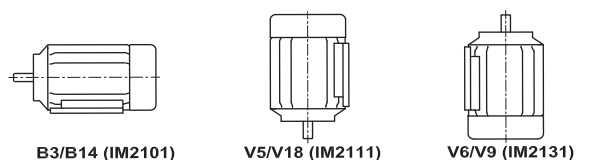

Connection diagrams three phase motors with cage rotor

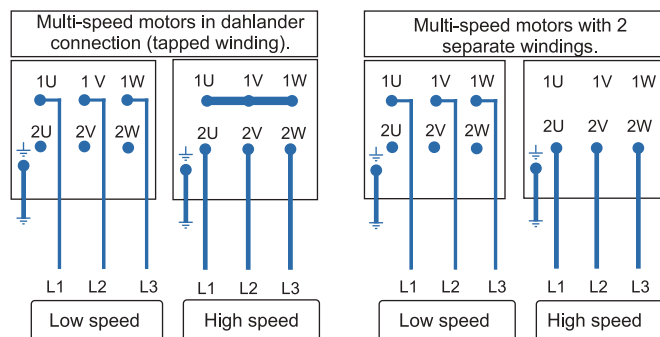
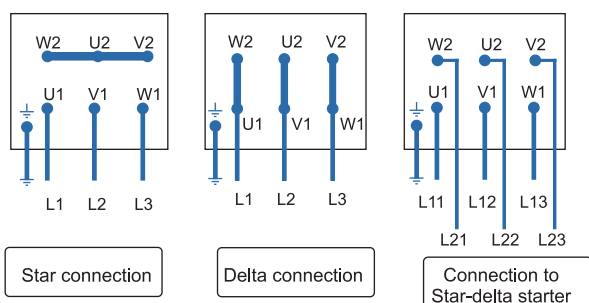

Rating plates

ENERTECH ELECTRIC MOTORS (AUSTRALIA)							
3 PHASE ASYNCHRONOUS MOTOR							
TYPE				S/N			
INS.CL.		IP		CODE		DUTY	
AMB.TEMP		°C					
BEARING DE		NDE		WEIGHT		KG	
VOLTS	CONN.	Hz	kW	RPM	AMP	Cos φ	EFF.%

ENERTECH ELECTRIC MOTORS (AUSTRALIA)							
SINGLE PHASE ASYNCHRONOUS MOTOR							
TYPE				S/N			
INS.CL.		IP		CODE		DUTY	
AMB.TEMP		°C					
BEARING DE		NDE		WEIGHT		KG	
VOLTS	Hz	kW	RPM	AMP	Cos φ	EFF.%	
STAR/RUN CAP				uF	V	uF	V

Electrical Design

Voltage and frequency

Standard Aluminium motors are designed for a power supply of three phase 400V, 50Hz. Motors can be manufactured for any supply between 100V and 1100V and frequencies other than 50Hz. Standard ESA motors wound for a certain voltage at 50Hz can also operate at other voltages at 50Hz and 60Hz without modification, subject to the changes in their data.

Motor wound for 50Hz at rated voltage	Connected to	Data in percentage of values at 50Hz and rated voltage						
		Output	r/min	I _N	I _L /I _N	T _N	T _L /T _N	T _B /T _N
380V	400V 50Hz	100	100	95	110	100	110	110
	380V 60Hz	100	120	98	83	83	70	85
	400V 60Hz	105	120	98	90	87	80	90
	415V 60Hz	110	120	98	95	91	85	93
	440V 60Hz	115	120	100	100	96	95	98
400V	460V 60Hz	120	120	100	105	100	100	103
	380V 50Hz	100	100	105	91	100	90	90
	415V 50Hz	100	100	96	108	100	108	108
	400V 60Hz	100	120	98	83	83	70	85
	415V 60Hz	104	120	98	89	86	75	88
	440V 60Hz	110	120	98	95	91	85	93
415V	460V 60Hz	115	120	100	100	96	93	98
	480V 60Hz	120	120	100	105	100	100	103
	380V 50Hz*	100	100	109	84	100	84	84
	400V 50Hz	100	100	104	93	100	93	93
	440V 50Hz	100	100	94	112	100	112	112
	415V 60Hz	100	120	98	83	83	70	85
525V	440V 60Hz	105	120	98	90	87	80	90
	460V 60Hz	110	120	98	95	91	85	94
	480V 60Hz	115	120	100	100	96	95	98
	550V 50Hz	100	100	95	110	100	110	110
	525V 60Hz	100	120	98	83	83	70	85
	550V 60Hz	105	120	98	90	87	80	90
600V	575V 60Hz	110	120	98	95	91	85	94
	600V 60Hz	115	120	100	100	96	95	98

* Not applicable for motors with F class temperature rise.

- 1) I_N = Full load current T_N = Full load torque
- I_L/I_N = Locked rotor current/ full load current
- T_L/T_N = Locked rotor torque/ full load torque
- T_B/T_N = Breakdown torque/full load torque

Standard torque values for alternative supplies are obtainable only with special windings. For these purpose-built motors the performance data is the same as for 400V motors except for the currents which are calculated with the accompanying formula:

Where:

$$I_x = \frac{400 \times I_N}{U_x}$$

- I_x = Current
- I_N = Full load current at 400 volt
- U_x = Design voltage

Temperature and altitude

Rated power specified in the performance data tables apply for standard ambient conditions of 40°C at 1000m above sea level. Where temperature or altitude differ from the standard, multiplication factors in the table below should be used.

Ambient temperature	Temperature factor	Altitude above sea level	Altitude factor
30°C	1.06	1000m	1.00
35°C	1.03	1500m	0.98
40°C	1.00	2000m	0.94
45°C	0.97	2500m	0.91
50°C	0.93	3000m	0.87
55°C	0.88	3500m	0.82
60°C	0.82	4000m	0.77

$$\text{Effective Power} = \frac{\text{Rated Power}}{\text{Temperature Factor} \times \text{Altitude Factor}}$$

Example 1:

Effective Power required = 15 kW

Air temperature = 50°C (factor 0.93)

Altitude = 2500 metres (factor 0.91)

$$\text{Rated power required} = \frac{15}{0.93 \times 0.91} = 17.7\text{kW}$$

The appropriate motor is one with a rated power above the required, being 18.5 kW.

Example 2:

Rated power = 11 kW

Air temperature = 50°C (factor 0.93)

Altitude = 1500 metres (factor 0.98)

$$\text{Effective Power} = 11 \times 0.93 \times 0.98 = 10.0 \text{ kW}$$

Rotation

For clockwise rotation, viewed from drive end, standard three phase Aluminium motors terminal markings coincide with the sequence of the phase line conductors. For counter clockwise rotation, viewed from drive end, two of the line conductors have to be reversed. This is made clear in the table of connection diagrams three phase motors with cage rotor (page 9).



Duty

Aluminium motors are supplied suitable for S1 operation (continuous operation under rated load). When the motor is operated under any other type of duty the following information should be supplied to determine the correct motor size:

- Type and frequency of switching cycles as per duty factors S3 to S7 and duty cycle factor.
- Load torque variation during motor acceleration and braking (in graphical form).
- Moment of inertia of the load on the motor shaft.
- Type of braking (eg mechanical electrical through phase reversal or DC injection)

Permissible output

Apply the factors of the expanding table to the output rating for motors with duty cycles that are not continuous. For other duties (S4, S5, S8 and S7) contact us for appropriate duty cycle factors.

	Poles	Duty cycle factor		
		For frames 80 to 132	For frames 160 to 250	For frames 280 to 355
Short-time duty, S2				
30 min	2	1.05	1.20	1.20
	4 to 8	1.10	1.20	1.20
60 min	2 to 8	1.00	1.10	1.10
Intermittent duty, S3				
15%	2	1.15	1.45	1.40
	4 to 8	1.40	1.40	1.40
25%	2	1.10	1.30	1.30
	4 to 8	1.30	1.25	1.30
40%	2	1.10	1.10	1.20
	4 to 8	1.20	1.08	1.20
60%	2	1.05	1.07	1.10
	4 to 8	1.10	1.05	1.10

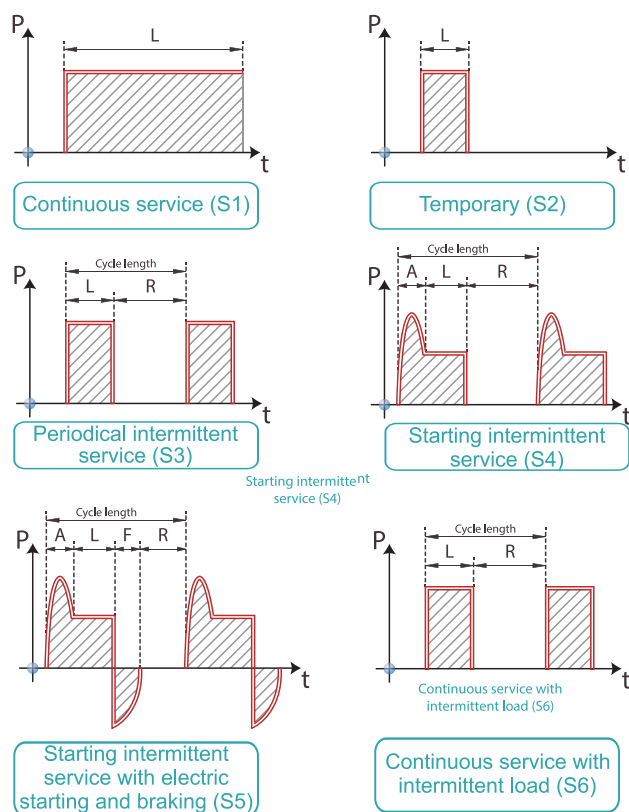

Explanation

D = Cycle length
 L = Load time R = Resting time
 A = Starting time F = Braking time

Intermittent ratio calculation in percentage

S3 = $L/(D) \times 100$ S4 = $(A+L)/(D) \times 100$
 S5 = $(A+L+F)/D \times 100$ S6 = $L/(D) \times 100$

Connection

A motor's rated voltage must agree with the power supply line-to-line voltage. It is carefully to ensure the correct connection to the motor terminals.

Internal connections, voltages and VF drive selection

Standard terminal connections for motors 3kW and below is 230V delta / 400V star. These motors are designed for 400V Direct On Line (D.O.L.) starting, when connected in the star configuration. They are also suitable for operation with 230V three phase variable frequency drives. when connected in the delta configuration. Standard terminal connections for motors 4kW and above is 400V delta / 690V star. These motors are designed for 400V Direct On Line (D.O.L.) starting, when connected in the delta configuration. They are also suitable for operation with 400V three phase variable frequency drives. Alternatively they can be operated D.O.L. in the star configuration from a 690V supply or with a 690V variable frequency drive. In this case the drive must be supplied with an output reactor to protect the winding insulation. These size motors are also suitable for 400V star-delta starting as described below. Motor connected for D.O.L. starting with bridges in place for star connection (3kW and below).

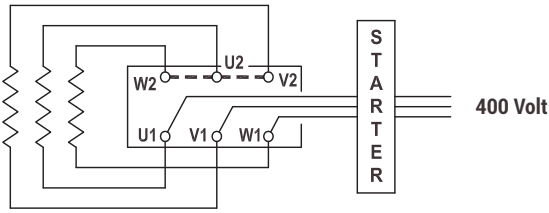

Motor connected for D.O.L starting with bridges in place for delta connection (4kW and above).

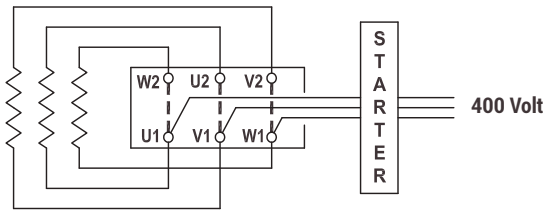

Starting

All of the following starter options are available and are the best supplied together with the motor.

D.O.L Starters

When an electric motor is started by direct connection to the power supply (D.O.L.), it draws a high current, called the starting current, which is approximately equal in magnitude to the locked rotor current I_L . As listed in the performance data, locked rotor current can be up to 8 times the rated current I_n of the motor. In circumstances where the motor starts under no load or where high starting torque is not required, it is preferable to reduce the starting current by one of the following means.

Star - Delta starting

The Aluminium motors 4kW and above are suitable for the star-delta starting method. Through the use of a star-delta starter, the motor terminals are connected in the star configuration during starting, and reconnected to the delta configuration when running. The benefits of this starting method are a significantly lower starting current, to a value about 1/3 of the D.O.L. starting current, and a corresponding starting torque also reduced to about 1/3 of its D.O.L. value. It should be noted that a second current surge occurs on change over to the delta connection. The level of this surge will depend on the speed the motor has reached at the moment of change over.

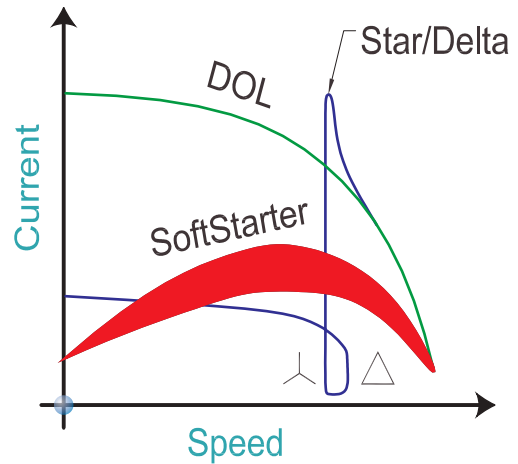

VVVF Drives

Variable Voltage Variable Frequency drives are primarily recognized for their ability to manipulate power from a constant 3 phase 50/60Hz supply converting it to variable voltage and variable frequency power. This enables the speed of the motor to be matched to its load in a flexible and energy efficient manner. The only way of producing starting torque equal to full load torque with kill load current is by using VVVF drives. The functionally flexible VVVF drive is also commonly used to reduce energy consumption on fans, pumps and compressors and offers a simple and repeatable method of changing speeds or flow rates.

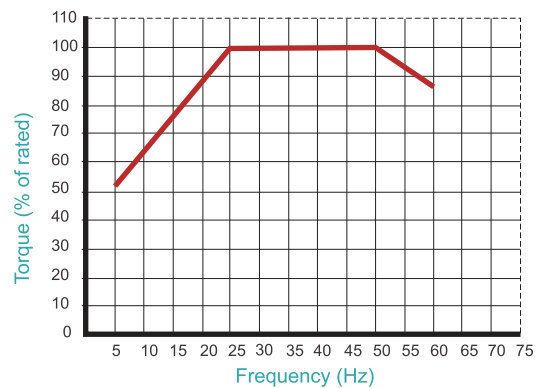

EDM Concerns

Capacitive voltages in the rotor can be generated due to an effect caused by harmonics in the waveform causing voltage discharge to earth through the bearings. This discharge results in etching of the bearing running surfaces. This effect is known as Electrical Discharge Machining (EDM). It can be control with the fitment of appropriate filters to the drive. To further reduce the of EDM, an insulated non drive bearing can be used.



Insulation

Our standard motors have insulation class F while the temperature rise is for Class B ensuring longer service life.

Upon the customer's request, H class insulation motors are manufactured.

Under specified measuring conditions in accordance with IEC 60034-1 standard, insulation class F for an electric motor means that at ambient temperature of 40°C the temperature rise of its windings may be max. 105°C with the additional temperature margin of 10°C.

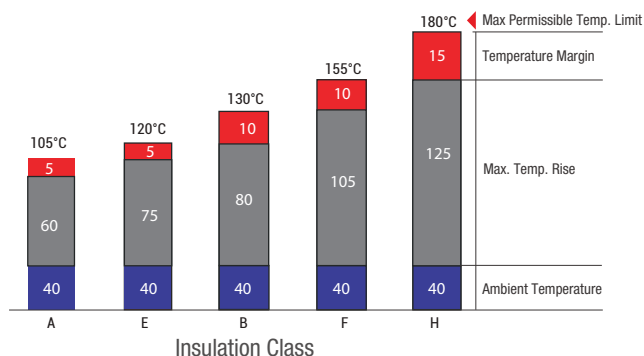

Thermal protection

Motors can be protected against excessive temperature rise by inserting, at various positions within the windings, thermal probes which can either give a warning signal or cut off the supply to the motor in the event of a temperature abnormality. The units fitted to Aluminium motors, frame sizes 160 and above, are PTC thermistors. These thermovaryable resistors, with positive temperature co-efficient, are fitted one per phase, series connected and are terminated in a terminal strip located in the terminal box. Trip temperature is 155°C (180°C for Aluminium motor class H). Additional 130°C thermistors can be fitted as an option for alarm connection.

Speed at partial loads

The relationship between motor speed and degree of loading on an Aluminium motor is approximately linear up to the rated load. This is expressed graphically in the accompanying drawing.

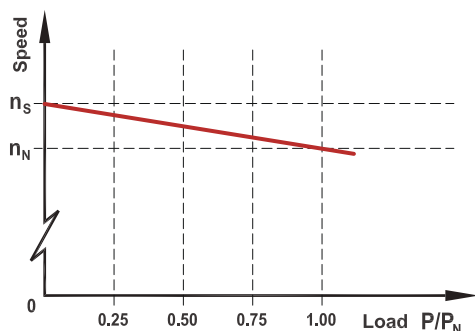

Where:

- n_N = full load speed
- n_s = asynchronous speed
- P/P_N = partial load factor

Current at partial loads

Current at partial loads can be calculated using the following formula:

$$I_x = \frac{P_{out_x}}{\sqrt{3} \times U_N \times \cos\phi_x \times \eta_x} \times 10^5$$

Where:

- I_x = partial load current (amps)
- P_{out_x} = partial load (kW)
- U_N = rated voltage
- $\cos\phi_x$ = partial load power factor
- η_x = partial load efficiency (%)

Torque characteristics

Typical characteristics of torque behaviour relative to speed are shown in the torque speed curve example below .

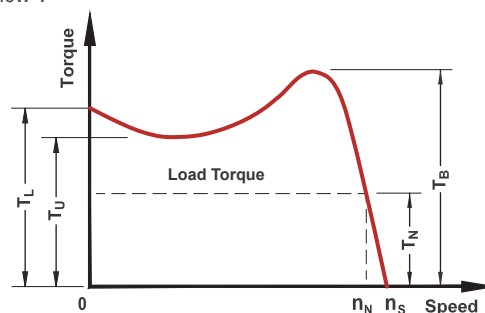

Where:

- T_N = full load torque
- T_B = break down torque
- T_L = locked rotor torque
- n_N = full load speed
- T_U = pull-up torque
- n_s = asynchronous speed

Aluminium motors all exceed the minimum starting torque requirements for Design N (Normal torque) as specified in IEC60034-12, and in most cases meet the requirements of Design H (High torque). Rated torque can be calculated with the following formula:

$$T_N = \frac{9550 \times P_N}{n_N}$$

Where:

- T_N = full load torque (Nm)
- P_N = full load output power (kW)
- n_N = full load speed (r/min)

Design features

Permissible radial loads on the shaft with standard bearings

The values of radial load calculated considering:

- Frequency: 50Hz.
- Temperature not exceeding 90°C.
- 30,000 hours of life for 2-pole motors;
- 60,000 hours of life for 4,6,8-pole motors.

For operation at 60Hz, the values have to be reduced by 6% in order to achieve the same useful life. For double speed motors, consider always the higher speed.

*The distance to the point of action of force F_R from the shoulder of the shaft must not exceed the length of the shaft end.

Forces of belt drive on the shaft tight side when the belt tensioners is calculated by the following formula:

$$F_R = 2 \sigma_0 F \sin \frac{\alpha_1}{2} z \text{ (N)}$$

Where:

σ_0 : The initial tension. (N) (trapezoid belt, flatbelt)

F : The cross-sectional area of the belt (cm²)

α_1 : Arc of contact small (belt) pulley

$$+ \alpha_1 = 180^\circ - (d_2 - d_1) \frac{57^\circ}{a} \quad (\alpha_1 > 120^\circ)$$

+ d_1 : Diameter of small (belt) pulley

+ d_2 : Diameter of large (belt) pulley

+ a : Center distance of 2(belt) pulley

z : Number of belt

Type of belt scales	The cross-sectional area F(cm ²)
A	0.81
B	1.38
C	2.3
D	4.76
E	6.92

Deflection Amount T (mm)

$$T = \frac{a}{64}$$

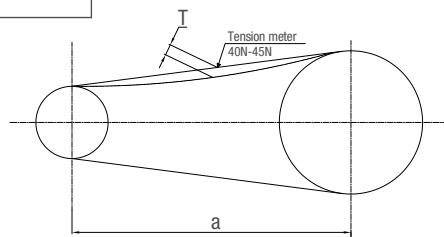

Example: there is 1 trapezoid belt drive

- $d_1 = 310\text{mm}$
- $d_2 = 460\text{mm}$
- $a = 1300\text{mm}$
- $z = 8$

The angle of the wheel hug small belt

$$\begin{aligned} \alpha_1 &= 180^\circ - (d_2 - d_1) \frac{57^\circ}{a} \\ &= 180^\circ - (460 - 310) \times 57 / 1300 = 173.4^\circ \end{aligned}$$

Forces of belt drive on the shaft tight side when the belt tensioners accordance stretch panel

$$F_R = 2 \sigma_0 F \sin \frac{\alpha_1}{2} z \text{ (N)}$$

$$= 2 \times 150 \times 2.3 \times 0.998 \times 8 = 5\,509 \text{ N}$$

Frame size	Pole number	Permissible radial load F_R [N]	
		Ball bearings	Roller bearings
63	2	365	---
	4	365	---
	6	410	---
	8	455	---
71	2	455	---
	4	450	---
	6	515	---
	8	565	---
80	2	590	---
	4	590	---
	6	670	---
	8	735	---
90	2	670	---
	4	660	---
	6	750	---
	8	830	---
100	2	1850	---
	4	915	---
	6	1045	---
	8	1150	---
112	2	1360	---
	4	1350	---
	6	1545	---
	8	1700	---
132	2	1955	---
	4	1930	---
	6	2210	---
	8	2240	---
160	2	2500	5460
	4	2480	5617
	6	2820	5722
	8	3115	5775
180	2	3275	6195
	4	3175	6720
	6	3600	7035
	8	4000	7140
200	2	4250	9240
	4	4325	9975
	6	5150	10290
	8	5275	10447
225	2	5075	11340
	4	4925	12180
	6	5575	12600
	8	6050	12810
250	2	5025	13230
	4	5475	15225
	6	5595	15750
	8	5970	15907
280	2	5000	14700
	4	5150	15225
	6	6300	15750
	8	7200	17325
315 S-M	2	5000	13650
	4	5700	26775
	6	6700	27825
	8	7600	28350
315 L	2	6200	13020
	4	6450	23625
	6	7300	26250
	8	8200	29400
355L	2	3250	---
	4	8400	---
	6	8900	---
	8	8900	---



Permissible axial loads on the shaft with standard bearings

If the shaft end is loaded at X_{max} with the permissible radial load F_R , an additional axial load is allowed.

If the permissible radial load is not fully utilized, higher loads are possible in axial direction (Values on request).

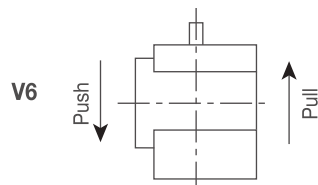
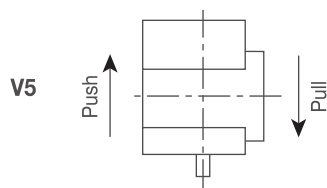
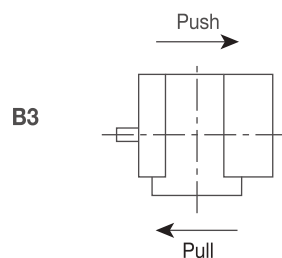
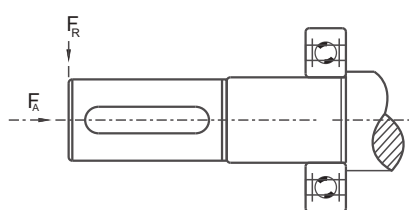

Frame size	Pole number	Limit axial load with F_R at $X_{max} = F_A$ [N]			
		Ball bearings		Roller bearings	
		B3 push/pull	V5/V6 push/pull	B3 push/pull	V5/V6 push/pull
63	2	120	110	---	---
	4	120	110	---	---
	6	140	130	---	---
	8	160	150	---	---
71	2	140	130	---	---
	4	140	120	---	---
	6	170	150	---	---
	8	190	170	---	---
80	2	190	170	---	---
	4	190	160	---	---
	6	220	190	---	---
	8	250	220	---	---
90	2	200	170	---	---
	4	200	160	---	---
	6	240	190	---	---
	8	270	220	---	---
100	2	280	230	---	---
	4	280	220	---	---
	6	330	260	---	---
	8	370	300	---	---
112	2	410	330	---	---
	4	410	320	---	---
	6	480	370	---	---
	8	540	430	---	---
132	2	590	430	---	---
	4	590	380	---	---
	6	690	470	---	---
	8	780	560	---	---
160	2	750	490	1000	700
	4	750	450	1200	840
	6	880	520	1300	910
	8	1000	640	1400	980
180	2	880	950	1000	700
	4	880	1150	1250	875
	6	1030	1350	1350	945
	8	1160	1550	1550	1085
200	2	1160	1100	1100	770
	4	1160	1200	1200	840
	6	1360	1400	1400	980
	8	1520	1600	1600	1120
225	2	1300	1250	1250	875
	4	1300	1350	1350	945
	6	1520	1600	1600	1120
	8	1710	1850	1850	1295
250	2	1460	1300	1300	910
	4	1460	1400	1400	980
	6	1710	1600	1600	1120
	8	1920	1920	1900	1330
280	2	5500	3850	3700	2590
	4	5500	3850	3700	2590
	6	6500	4550	4000	2800
	8	7400	5180	4500	3150
315 S-M	2	5500	3850	3700	2590
	4	5800	4060	3500	2450
	6	6800	4760	4000	2800
	8	7650	5355	4500	3150
315 L	2	2200	1540	3850	2695
	4	2200	1540	3800	2660
	6	2500	1750	4600	3220
	8	3000	2100	5500	3850
355L	2	2000	3690	---	---
	4	6000	1880	---	---
	6	7000	300	---	---
	8	8000	300	---	---

Efficiency data classification

Output (kW)	ESA									
	2P			4P			6P			8P
	IE1	IE2	IE3	IE1	IE2	IE3	IE1	IE2	IE3	IE1
0.06	-	-	-	50.0	-	-	-	-	-	-
0.09	50.0	-	-	52.0	-	-	42.0	-	-	48.0
0.12	61.0	-	-	52.0	-	-	45.0	-	-	51.0
0.18	63.0	-	-	55.0	-	-	56.0	-	-	51.0
0.25	65.0	-	-	60.0	-	-	59.0	-	-	56.0
0.37	70.0	-	-	65.0	-	-	62.0	-	-	63.0
0.55	71.0	-	-	67.0	-	-	67.0	-	-	66.0
0.75	73.0	77.4	80.7	72.0	79.6	82.5	69.0	76.0	78.9	66.0
1.1	76.2	80.0	82.7	76.2	81.4	84.1	72.0	78.1	81.0	72.0
1.5	78.5	81.4	84.2	78.5	82.8	85.3	74.0	80.0	82.5	74.0
2.2	81.0	83.2	85.9	81.0	84.3	86.7	78.0	81.8	84.3	75.0
3	82.6	84.6	87.1	82.6	85.5	87.7	79.0	83.3	85.6	77.0
4	84.2	86.0	88.1	84.2	86.6	88.6	80.5	84.6	86.8	80.0
5.5	85.7	87.2	89.2	85.7	87.9	89.6	83.0	86.0	88.0	83.5
7.5	87.0	88.1	90.1	87.0	88.7	90.4	86.0	87.5	89.1	88.0
9.2	88.0	-	-	87.5	-	-	-	-	-	-
11	88.4	-	-	88.4	-	-	-	-	-	-
11	88.4	-	-	88.4	-	-	87.5	-	-	87.4

Output (kW)	ESS			ESD	
	2P	4P	6P	2P	4P
0.09	54	50	46	-	-
0.12	60	52	54	-	55
0.18	62	54	55	63	56
0.25	65	56	57	64	60
0.37	66	58	62	65	63
0.55	71	64	63	68	66
0.75	73	68	66	72	69
1.1	74	72	67	73	71
1.5	76	74	-	74	73
2.2	77	78	-	75	74
3	77	79	-	77	75
3.7	-	-	-	78	77
4	-	-	-	80	80

This data is provided for guidance only. Results are guaranteed only when confirmed by test results.



ESA SERIES

THREE-PHASE ALUMINIUM MOTORS



ENERTECHMOTORS.COM.AU



Performance data of ESA

2 Pole - 3000 rpm asynchronous speed 50Hz

IE1

PERFORMANCE DATA ESA

Output (kW)	Frame size	Full load speed (RPM)	Current full load I_n 50 Hz					Efficiency at 100% full load	Power factor $\cos \phi$ at 100% full load	Locked rotor I_{st}/I_n (A)	Torque			Moment of inertia $J=1/4GD^2$ (kg x m ²)	Noise level dB (A)	Net weight (kg)
			220V (A)	380V (A)	400V (A)	415V (A)	660V (A)				Full load torque T_N (Nm)	Locked rotor torque T_{st}/T_N	Break down torque T_M/T_N			
0.09	561	2710	0.66	0.38	0.36	0.35	50.0	0.72	4.0	0.3	2.2	2.3	0.0001	58	2.6	
0.12	562	2700	0.72	0.42	0.39	0.38	61.0	0.72	4.0	0.4	2.2	2.3	0.0001	58	3.0	
0.18	631	2710	1.01	0.59	0.56	0.54	63.0	0.74	6.0	0.6	2.2	2.4	0.0002	61	4.0	
0.25	632	2710	1.29	0.75	0.71	0.69	65.0	0.78	6.0	0.9	2.2	2.4	0.0002	61	4.2	
0.37	711	2730	1.76	1.02	0.97	0.93	70.0	0.79	6.0	1.3	2.2	2.4	0.0003	64	4.3	
0.55	712	2760	2.57	1.49	1.42	1.36	71.0	0.79	6.0	1.9	2.2	2.4	0.0004	64	6.0	
0.75	801	2770	3.21	1.86	1.77	1.70	73.0	0.84	6.0	2.6	2.2	2.4	0.0009	67	8.7	
1.1	802	2770	4.56	2.64	2.51	2.42	76.2	0.83	6.0	3.8	2.2	2.4	0.0011	67	10.0	
1.5	90S	2840	5.97	3.46	3.28	3.16	78.5	0.84	6.0	5.0	2.2	2.4	0.0016	72	12.0	
2.2	90L1	2840	8.39	4.85	4.61	4.45	81.0	0.85	6.0	7.4	2.2	2.4	0.0021	72	14.5	
3	100L	2840	10.96	6.34	6.03	5.81	82.6	0.87	7.0	10.1	2.2	2.3	0.0035	76	20.0	
4	112M1	2880		8.30	7.88	7.60	4.78	84.2	0.87	7.5	13.3	2.2	2.3	0.0058	77	26.0
5.5	132S1	2900		11.08	10.53	10.15	6.38	85.7	0.88	7.5	18.1	2.0	2.2	0.0112	80	38.4
7.5	132S2	2920		14.88	14.14	13.63	8.57	87.0	0.88	7.5	24.5	2.0	2.2	0.0138	80	41.3
9.2	132M1	2930		17.85	16.96	16.34	10.28	88.0	0.89	7.5	30.0	2.0	2.2	0.0166	81	48.2
11	132M2	2930		21.01	19.96	19.24	12.10	88.4	0.90	7.5	35.9	2.0	2.2	0.0173	83	52.5
11	160M1	2940		21.01	19.96	19.24	12.10	88.4	0.90	7.5	35.7	2.0	2.2	0.0412	86	76.0

This data is provided for guidance only. Results are guaranteed only when confirmed by test results.



4 Pole - 1500 rpm asynchronous speed 50Hz

IE1

Output (kW)	Frame size	Full load speed (RPM)	Current full load I_n 50 Hz					Efficiency at 100% full load	Power factor $\cos \phi$ at 100% full load	Locked rotor I_{sr}/I_n (A)	Torque			Moment of inertia $J=1/4GD^2$ (kg x m ²)	Noise level dB (A)	Net weight (kg)
			220V (A)	380V (A)	400V (A)	415V (A)	660V (A)				Full load torque T_N (Nm)	Locked rotor torque T_{sr}/T_N	Break down torque T_M/T_N			
0.06	561	1360	0.56	0.33	0.31	0.30	50.0	0.56	4.0	0.4	2.3	2.4	0.0002	50	2.9	
0.09	562	1360	0.77	0.45	0.42	0.41	52.0	0.59	4.0	0.6	2.3	2.4	0.0002	50	3.2	
0.12	631	1360	0.95	0.55	0.52	0.50	52.0	0.64	4.0	0.8	2.2	2.4	0.0003	52	3.7	
0.18	632	1310	1.43	0.83	0.79	0.76	55.0	0.60	4.0	1.3	2.2	2.4	0.0003	52	4.3	
0.25	711	1350	1.52	0.88	0.84	0.81	60.0	0.72	6.0	1.8	2.2	2.4	0.0006	55	5.0	
0.37	712	1370	2.07	1.20	1.14	1.10	65.0	0.72	6.0	2.6	2.2	2.4	0.0007	55	5.8	
0.55	801	1370	2.87	1.66	1.58	1.52	67.0	0.75	6.0	3.8	2.2	2.4	0.0014	58	8.1	
0.75	802	1380	3.60	2.07	1.98	1.91	72.0	0.76	6.0	5.2	2.2	2.4	0.0018	58	9.1	
1.1	90S	1400	4.80	2.78	2.64	2.54	76.2	0.79	6.0	7.5	2.2	2.4	0.0024	61	11.7	
1.5	90L	1400	6.35	3.68	3.49	3.37	78.5	0.79	6.0	10.2	2.2	2.4	0.0032	61	14.4	
2.2	100L1	1420	8.80	5.09	4.84	4.67	81.0	0.81	7.0	14.8	2.2	2.3	0.0060	64	19.2	
3	100L2	1420	11.77	6.81	6.47	6.24	82.6	0.81	7.0	20.2	2.2	2.3	0.0076	64	22.5	
4	112M	1430		8.70	8.26	7.96	5.01	84.2	0.83	7.0	26.7	2.2	2.2	0.0121	65	29.0
5.5	132S	1450		11.61	11.03	10.63	6.68	85.7	0.84	7.0	36.2	2.2	2.2	0.0248	71	39.0
7.5	132M1	1450		15.41	14.64	14.11	8.87	87.0	0.85	7.0	49.4	2.2	2.2	0.0331	71	48.6
9.2	132L1	1460		18.79	17.85	17.21	10.82	87.5	0.85	7.5	60.2	2.2	2.2	0.0393	74	56.5
11	132L2	1460		21.98	20.88	20.13	12.66	88.4	0.86	7.0	72.0	2.2	2.2	0.0455	74	64.0
11	160M	1460		21.73	20.64	19.90	12.51	88.4	0.87	7.0	72.0	2.2	2.2	0.0774	75	73.0

This data is provided for guidance only. Results are guaranteed only when confirmed by test results.

6 Pole - 1000 rpm asynchronous speed 50Hz

IE1

PERFORMANCE DATA ESA

Output (kW)	Frame size	Full load speed (RPM)	Current full load I_N 50 Hz					Efficiency at 100% full load	Power factor $\cos \varphi$ at 100% full load	Locked rotor I_{st}/I_N (A)	Torque			Moment of inertia $J=\frac{1}{2}GD^2$ (kg x m ²)	Noise level dB (A)	Net weight (kg)
			220V (A)	380V (A)	400V (A)	415V (A)	660V (A)				Full load torque T_N (Nm)	Locked rotor torque T_{st}/T_N	Break down torque T_M/T_N			
0.09	631	840	0.92	0.53	0.51	0.49	42.0	0.61	3.5	1.0	2.0	2.0	0.0004	50	4.2	
0.12	632	850	1.13	0.65	0.62	0.60	45.0	0.62	3.5	1.3	2.0	2.0	0.0005	50	4.5	
0.18	711	880	1.28	0.74	0.70	0.68	56.0	0.66	4.0	2.0	1.6	1.7	0.0008	52	5.6	
0.25	712	900	1.64	0.95	0.90	0.87	59.0	0.68	4.0	2.7	2.1	2.2	0.0010	52	6.0	
0.37	801	900	2.30	1.33	1.27	1.22	62.0	0.68	4.0	3.9	1.9	1.9	0.0016	56	8.1	
0.55	802	900	3.03	1.76	1.67	1.61	67.0	0.71	4.0	5.8	2.0	2.3	0.0021	56	9.6	
0.75	90S	920	4.02	2.33	2.21	2.13	69.0	0.71	5.5	7.8	2.2	2.2	0.0031	59	11.3	
1.1	90L	925	5.49	3.18	3.02	2.91	72.0	0.73	5.5	11.4	2.2	2.2	0.0041	59	14.4	
1.5	100L	945	7.00	4.05	3.85	3.71	74.0	0.76	6.0	15.2	2.2	2.2	0.0051	61	18.8	
2.2	112M	955	9.87	5.71	5.43	5.23	78.0	0.75	6.0	22.0	2.2	2.2	0.0138	64	25.0	
3	132S	960	13.11	7.59	7.21	6.95	79.0	0.76	6.5	29.8	2.0	2.0	0.0299	64	35.0	
4	132M1	960		9.93	9.44	9.10	80.5	0.76	6.5	39.8	2.0	2.0	0.0373	68	47.6	
5.5	132M2	960		13.08	12.42	11.97	83.0	0.77	6.5	54.7	2.0	2.0	0.0490	68	50.7	
7.5	160M	960		16.56	15.73	15.17	86.0	0.80	6.5	74.6	2.0	2.2	0.0845	68	70.0	
11	160L	960		24.18	22.97	22.14	87.5	0.79	6.5	109.4	2.0	2.2	0.1182	73	87.0	

This data is provided for guidance only. Results are guaranteed only when confirmed by test results.



8 Pole - 750 rpm asynchronous speed 50Hz

IE1

Output (kW)	Frame size	Full load speed (RPM)	Current full load I_N 50 Hz					Efficiency at 100% full load	Power factor $\cos \phi$ at 100% full load	Locked rotor I_{st}/I_N (A)	Torque			Moment of inertia $J = \frac{1}{2}GD^2$ (kg x m ²)	Noise level dB (A)	Net weight (kg)
			220V (A)	380V (A)	400V (A)	415V (A)	660V (A)				Full load torque T_N (Nm)	Locked rotor torque T_{st}/T_N	Break down torque T_M/T_N			
0.09	711	680	0.88	0.51	0.48	0.47	48.0	0.56	3.0	1.3	1.5	1.7	0.0007	50	5.6	
0.12	712	690	1.05	0.61	0.58	0.55	51.0	0.59	2.7	1.7	1.6	1.7	0.0008	50	6.0	
0.18	801	680	1.52	0.88	0.84	0.80	51.0	0.61	2.8	2.5	1.5	1.7	0.0021	52	9.4	
0.25	802	680	1.92	1.11	1.06	1.02	56.0	0.61	2.7	3.5	1.6	2.0	0.0025	52	10.1	
0.37	90S	680	2.45	1.42	1.35	1.30	63.0	0.63	2.8	5.2	1.6	1.8	0.0031	56	12.5	
0.55	90L	680	3.36	1.95	1.85	1.78	66.0	0.65	3.0	7.7	1.6	1.8	0.0041	56	15.3	
0.75	100L1	710	4.45	2.58	2.45	2.36	66.0	0.67	3.5	10.1	1.7	2.1	0.0060	59	17.2	
1.1	100L2	710	5.81	3.36	3.20	3.08	72.0	0.69	3.5	14.8	1.7	2.1	0.0075	59	19.5	
1.5	112M1	710	7.82	4.53	4.30	4.15	74.0	0.68	4.2	20.2	1.8	2.1	0.0135	61	25.5	
2.2	132S	720	10.84	6.28	5.95	5.75	75.0	0.71	5.5	29.2	2.0	2.0	0.0290	64	34.2	
3	132M	720	14.01	8.11	7.70	7.43	77.0	0.73	5.5	39.8	2.0	2.0	0.0380	64	40.0	
4	160M1	730		10.41	9.89	9.53	5.99	80.0	0.73	6.0	52.3	1.9	2.1	0.0672	68	59.0
5.5	160M2	720		13.52	12.85	12.38	7.79	83.5	0.74	6.0	73.0	2.0	2.2	0.0906	68	69.0
7.5	160L	720		17.88	16.98	16.37	10.29	85.0	0.75	6.0	99.5	1.9	2.2	0.1241	68	87.0
11	180L	715		26.20	24.89	23.99	15.08	87.4	0.73	6.0	146.9	1.9	2.2	0.2611	78	125.0

This data is provided for guidance only. Results are guaranteed only when confirmed by test results.

IE2

Output (kW)	Frame size	Full load speed (RPM)	Current full load I_N 50 Hz					Efficiency at 100% full load	Power factor $\cos \phi$ at 100% full load	Locked rotor I_{sc}/I_N (A)	Torque			Moment of inertia $J = \frac{1}{2}GD^2$ (kg x m ²)	Noise level dB (A)	Net weight (kg)
			220V (A)	380V (A)	400V (A)	415V (A)	660V (A)				Full load torque T_N (Nm)	Locked rotor torque T_{st}/T_N	Break down torque T_M/T_N			

3000 rpm = 2 Poles

0.75	801	2840	3.18	1.84	1.75	1.69	77.4	0.80	5.8	2.5	2.9	3.3	0.0009	67	8.9	
1.1	802	2850	4.40	2.55	2.42	2.33	80.0	0.82	6.8	3.7	3.5	3.6	0.0011	67	10.6	
1.5	90S	2850	5.83	3.37	3.20	3.09	81.4	0.83	6.9	5.0	3.5	3.6	0.0014	70	13.0	
2.2	90L1	2860	8.26	4.78	4.54	4.38	83.2	0.84	7.9	7.3	4.1	4.1	0.0022	72	16.1	
3	100L	2880	10.70	6.19	5.88	5.67	84.6	0.87	7.8	9.9	3.4	3.4	0.0030	76	22.7	
4	112M1	2890		7.94	7.54	7.27	4.57	86.0	0.89	7.5	13.2	2.7	3.3	0.0063	77	26.4
5.5	132S1	2900		10.77	10.23	9.86	6.20	87.2	0.89	7.7	18.1	2.4	3.0	0.0120	80	42.3
7.5	132S2	2910		14.53	13.81	13.31	8.37	88.1	0.89	8.4	24.6	2.6	3.2	0.0146	80	46.2

1500 rpm = 4 Poles

0.75	802	1410	3.25	1.88	1.79	1.72	79.6	0.76	5.3	5.1	2.8	3.0	0.0021	58	11.1	
1.1	90S	1420	4.55	2.63	2.50	2.41	81.4	0.78	6.7	7.4	3.8	2.6	0.0029	61	13.9	
1.5	90L	1420	6.02	3.48	3.31	3.19	82.8	0.79	7.2	10.1	4.0	2.7	0.0037	61	16.9	
2.2	100L1	1440	8.78	5.08	4.83	4.65	84.3	0.78	7.4	14.6	3.6	3.6	0.0073	64	22.4	
3	100L2	1440	11.51	6.66	6.33	6.10	85.5	0.80	7.8	19.9	3.8	3.5	0.0091	64	26.4	
4	112M	1440		8.66	8.23	7.93	4.99	86.6	0.81	7.1	26.5	3.1	2.9	0.0133	65	32.3
5.5	132S	1450		11.45	10.88	10.49	6.59	87.9	0.83	7.4	36.2	2.6	2.7	0.0277	71	43.0
7.5	132M1	1450		15.29	14.53	14.00	8.81	88.7	0.84	7.7	49.4	2.8	2.7	0.0359	71	52.6

1000 rpm = 6 Poles

0.75	90S	925	3.65	2.11	2.01	1.93	76.0	0.71	4.7	7.7	3.1	3.1	0.0034	59	13.0	
1.1	90L	930	5.13	2.97	2.82	2.72	78.1	0.72	5.0	11.3	3.2	3.2	0.0048	59	16.4	
1.5	100L	940	6.74	3.90	3.71	3.57	80.0	0.73	5.9	15.2	3.1	2.9	0.0096	61	21.6	
2.2	112M	945	9.41	5.45	5.18	4.99	81.8	0.75	5.5	22.2	2.6	2.8	0.0170	64	29.5	
3	132S	960	12.44	7.20	6.84	6.59	83.3	0.76	5.7	29.8	2.2	2.7	0.0299	64	35.2	
4	132M1	960		9.33	8.86	8.54	5.37	84.6	0.77	6.2	39.8	2.4	2.7	0.0403	68	45.0
5.5	132M2	960		12.62	11.99	11.56	7.27	86.0	0.77	6.7	54.7	2.6	2.7	0.0534	68	53.5
7.5	160M	970		16.91	16.07	15.49	9.74	87.5	0.77	5.6	73.8	2.0	2.8	0.0897	68	72.6

This data is provided for guidance only. Results are guaranteed only when confirmed by test results.



IE3

Output (kW)	Frame size	Full load speed (RPM)	Current full load I_n 50 Hz					Efficiency at 100% full load	Power factor $\cos \phi$ at 100% full load	Locked rotor I_{sr}/I_n (A)	Torque			Moment of inertia $J = \frac{1}{2}GD^2$ (kg x m ²)	Noise level dB (A)	Net weight (kg)
			220V (A)	380V (A)	400V (A)	415V (A)	660V (A)				Full load torque T_N (Nm)	Locked rotor torque T_{sr}/T_N	Break down torque T_M/T_N			

3000 rpm = 2 Poles

0.75	801	2880	2.94	1.70	1.62	1.56	80.7	0.83	5.5	2.5	1.8	3.5	0.0010	67	13.5	
1.1	802	2880	4.21	2.43	2.31	2.23	82.7	0.83	7.5	3.6	2.6	3.5	0.0013	67	15.0	
1.5	90S	2895	5.63	3.26	3.10	2.99	84.2	0.83	7.1	4.9	2.6	3.5	0.0022	72	19.0	
2.2	90L1	2895	7.91	4.58	4.35	4.19	85.9	0.85	7.0	7.3	2.0	3.0	0.0026	72	21.5	
3	100L	2895	10.27	5.95	5.65	5.45	87.1	0.88	8.6	9.9	2.0	3.2	0.0048	76	30.5	
4	112M1	2905		7.84	7.45	7.18	4.51	88.1	0.88	8.0	13.1	1.8	2.9	0.0075	77	34.0
5.5	132S1	2930		10.65	10.11	9.75	6.13	89.2	0.88	7.5	17.9	2.1	2.5	0.0152	80	49.5
7.5	132S2	2930		14.37	13.65	13.16	8.27	90.1	0.88	7.3	24.4	2.0	3.5	0.0190	80	55.0

1500 rpm = 4 Poles

0.75	802	1420	3.22	1.87	1.77	1.71	82.5	0.74	6.0	5.0	2.9	3.6	0.0023	58	16.0	
1.1	90S	1445	4.64	2.69	2.55	2.46	84.1	0.74	6.5	7.3	2.7	3.8	0.0038	61	20.0	
1.5	90L	1445	6.24	3.61	3.43	3.31	85.3	0.74	6.8	9.9	3.0	3.6	0.0047	61	22.5	
2.2	100L1	1435	8.54	4.94	4.70	4.53	86.7	0.78	7.2	14.6	2.5	3.5	0.0088	64	32.5	
3	100L2	1435	11.51	6.66	6.33	6.10	87.7	0.78	7.2	20.0	2.6	3.5	0.0111	64	38.5	
4	112M	1440		8.57	8.15	7.85	4.94	88.6	0.80	7.0	26.5	2.3	3.2	0.0153	65	44.0
5.5	132S	1460		11.66	11.08	10.68	6.71	89.6	0.80	7.1	36.0	2.7	3.5	0.0345	71	54.5
7.5	132M1	1460		15.37	14.60	14.08	8.85	90.4	0.82	7.2	49.1	2.7	3.8	0.0436	72	66.0

1000 rpm = 6 Poles

0.75	90S	935	3.62	2.09	1.99	1.92	78.9	0.69	4.5	7.7	2.5	3.3	0.0041	59	20.0	
1.1	90L	945	5.17	2.99	2.84	2.74	81.0	0.69	4.4	11.1	1.7	3.3	0.0055	59	22.5	
1.5	100L	949	6.92	4.00	3.80	3.67	82.5	0.69	5.0	15.1	2.3	3.0	0.0091	61	30.0	
2.2	112M	955	9.65	5.58	5.31	5.11	84.3	0.71	5.5	22.0	2.6	3.0	0.0177	64	35.5	
3	132S	968	12.95	7.50	7.12	6.87	85.6	0.71	5.5	29.6	2.0	3.1	0.0338	65	46.0	
4	132M1	968		9.86	9.37	9.03	5.68	86.8	0.71	5.7	39.5	2.1	2.6	0.0440	68	55.0
5.5	132M2	968		12.66	12.03	11.59	7.29	88.0	0.75	6.0	54.3	1.7	2.6	0.0540	68	65.5
7.5	160M	970		16.61	15.78	15.21	9.56	89.1	0.77	5.9	73.8	1.7	2.5	0.1090	68	79.5

This data is provided for guidance only. Results are guaranteed only when confirmed by test results.

Dimension of ESA

IMB3

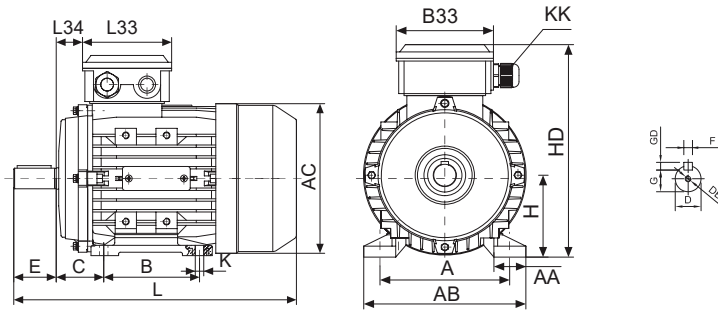

IMB5

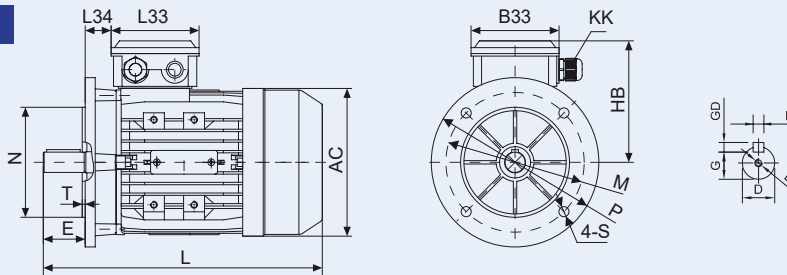

IMB35

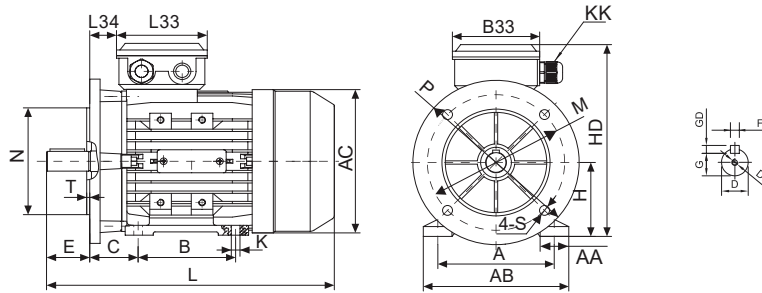

IMB14

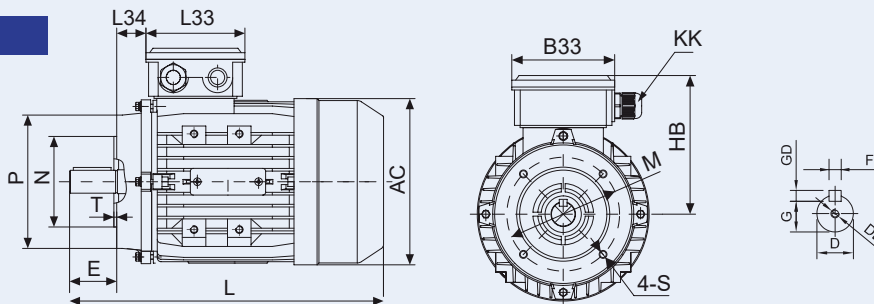

IMB34

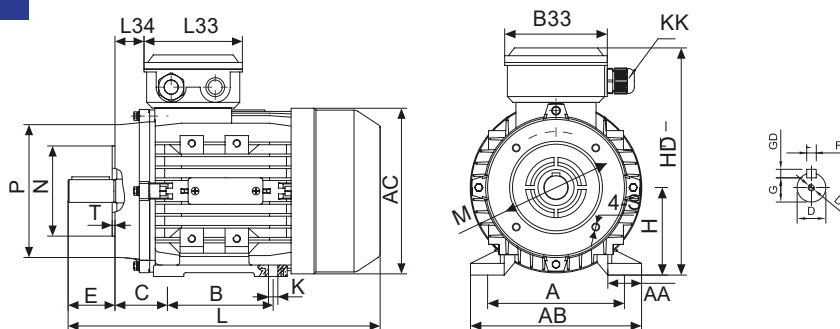

Frame size	General								Feet							
	B3, B5, B34, B35, B14								B3, B34, B35							
	AC	B33	HB	HD	KK	L	L33	L34	A	AA	AB	B	BB	C	H	K
56	117	88	100	156	-	196	88	14	90	20	110	71	90	36	56	6
63	130	94	108	171	M16	220	94	14	100	27	120	80	103	40	63	7
71	147	94	115	186	M20	260	94	20	112	28	132	90	105	45	71	7
80	163	105	133	213	M20	298	105	27	125	35	160	100	130	50	80	10
90S	183	105	139	229	M20	312	105	30	140	35	175	100	130	56	90	10
90L	183	105	139	229	M20	337	105	30	140	35	175	125	155	56	90	10
100L	205	105	152	252	M20	388	105	26	160	50	198	140	175	63	100	12
112M	229	112	167	279	M25	395	112	32	190	43	220	140	180	70	112	12
132S	265	112	186	318	M25	437	112	38	216	58	252	140	176	89	132	12
132M/L	265	112	186	318	M25	475	112	38	216	58	252	178	223	89	132	12
160M	313	147	250	410	M32	615	150	90	254	82	304	210	260	108	160	18
160L	313	147	250	410	M32	660	150	90	254	82	304	254	260	108	160	18
180L	313	-	275	455	M32	740	-	-	279	-	355	279	387	121	180	14.5

DIMENSION OF ESA

Frame size	Shaft						Flange									
	B3, B5, B34, B35, B14						B5, B35					B14, B34				
	D	DB	E	F	G	GD	M	N	P	S	T	M	N	P	S	T
56	9	M3	20	3	7.2	3	100	80	120	7	3	65	50	80	M5	2.5
63	11	M4	23	4	8.5	4	115	95	140	10	3	75	60	90	M5	2.5
71	14	M5	30	5	11	5	130	110	160	10	3.5	85	70	105	M6	2.5
80	19	M6	40	6	15.5	6	165	130	200	12	3.5	100	80	120	M6	3
90S	24	M8	50	8	20	7	165	130	200	12	3.5	115	95	140	M8	3
90L	24	M8	50	8	20	7	165	130	200	12	3.5	115	95	140	M8	3
100L	28	M10	60	8	24	7	215	180	250	15	4	130	110	160	M8	3.5
112M	28	M10	60	8	24	7	215	180	250	15	4	130	110	160	M8	3.5
132S	38	M12	80	10	33	8	265	230	300	15	4	165	130	200	M10	4
132M/L	38	M12	80	10	33	8	265	230	300	15	4	165	130	200	M10	4
160M	42	M16	110	12	37	9	300	250	350	19	5	215	180	250	M12	4
160L	42	M16	110	12	37	9	300	250	350	19	5	-	-	-	-	-
180L	48	M16	110	14	42.5	9	300	250	350	18.5	5	-	-	-	-	-

ESS SERIES

SINGLE-PHASE CAPACITOR RUN ASYNVCHRONOUS MOTORS ALUMINUM HOUSING



ENERTECHMOTORS.COM.AU



Performance data of ESS

Output (kW)	Frame size	Full load speed (RPM)	Current Full load I_N (A)	Efficiency at 100% full load	Power factor $\cos \phi$ at 100% full load	Locked rotor I_{st}/I_N (A)	Torque			Run Capacitor ($\mu\text{F}/\text{V}$)	Noise level dB (A)	Net weight (kg)
							Full load torque T_N (Nm)	Locked rotor torque T_{st}/T_N	Break down torque T_M/T_N			

3000 rpm = 2 Poles

0.18	631	2750	1.42	62	0.93	4.5	0.6	0.70	1.80	10 $\mu\text{F}/450\text{V}$	70	4.0
0.25	632	2750	1.88	65	0.93	6.0	0.9	0.65	1.75	12 $\mu\text{F}/450\text{V}$	70	4.7
0.37	711	2740	2.71	66	0.94	8.0	1.3	0.72	1.65	16 $\mu\text{F}/450\text{V}$	75	6.1
0.55	712	2760	3.71	71	0.95	14.0	1.9	0.70	1.80	20 $\mu\text{F}/450\text{V}$	75	7.7
0.75	801	2735	4.77	73	0.98	16.0	2.6	0.68	1.75	30 $\mu\text{F}/450\text{V}$	75	10.3
1.1	802	2720	6.89	74	0.98	23.0	3.9	0.65	1.80	40 $\mu\text{F}/450\text{V}$	78	11.6
1.5	90S	2755	9.15	76	0.98	31.0	5.2	0.65	1.80	50 $\mu\text{F}/450\text{V}$	80	14.6
2.2	90L1	2765	13.25	77	0.98	51.0	7.6	0.65	1.80	80 $\mu\text{F}/450\text{V}$	80	17.8
3	100L	2765	17.89	77	0.99	64.0	10.4	0.55	1.75	100 $\mu\text{F}/450\text{V}$	83	23.7

1500 rpm = 4 Poles

0.25	711	1320	2.16	56	0.94	5.0	1.8	0.75	1.60	16 $\mu\text{F}/450\text{V}$	65	6.2
0.37	712	1325	3.08	58	0.94	7.0	2.7	0.70	1.55	20 $\mu\text{F}/450\text{V}$	68	7.3
0.55	801	1340	4.16	64	0.94	11.0	3.9	0.70	1.70	25 $\mu\text{F}/450\text{V}$	73	10.1
0.75	802	1340	5.33	68	0.94	15.0	5.3	0.70	1.75	35 $\mu\text{F}/450\text{V}$	73	11.4
1.1	90S	1355	7.31	72	0.95	22.0	7.8	0.68	1.80	60 $\mu\text{F}/450\text{V}$	75	14.4
1.5	90L	1360	9.70	74	0.95	32.0	10.5	0.68	1.80	70 $\mu\text{F}/450\text{V}$	78	17.5
2.2	100L1	1390	13.22	78	0.97	49.0	15.1	0.48	1.75	80 $\mu\text{F}/450\text{V}$	80	24.5
3	100L2	1380	17.44	79	0.99	61.0	20.8	0.45	1.60	120 $\mu\text{F}/450\text{V}$	80	32.0

1000 rpm = 6 Poles

0.09	631	900	0.97	46	0.92	2.0	1.0	0.80	1.45	8 $\mu\text{F}/450\text{V}$	63	5.1
0.12	632	900	1.10	54	0.92	3.0	1.3	0.75	1.45	11 $\mu\text{F}/450\text{V}$	63	6.0
0.18	711	900	1.62	55	0.92	4.0	1.9	0.70	1.85	16 $\mu\text{F}/450\text{V}$	68	6.3
0.25	712	900	2.17	57	0.92	5.0	2.7	0.68	1.50	20 $\mu\text{F}/450\text{V}$	68	7.6
0.37	801	900	2.95	62	0.92	8.0	3.9	0.68	1.60	25 $\mu\text{F}/450\text{V}$	68	9.0
0.55	802	900	4.27	63	0.93	14.0	5.8	0.68	1.60	30 $\mu\text{F}/450\text{V}$	70	11.6
0.75	90S	900	5.44	66	0.95	16.0	8.0	0.65	1.60	40 $\mu\text{F}/450\text{V}$	70	13.5
1.1	90L	900	7.86	67	0.95	25.0	11.7	0.62	1.60	50 $\mu\text{F}/450\text{V}$	70	16.2

This data is provided for guidance only. Results are guaranteed only when confirmed by test results.

Dimension of ESS

IMB3

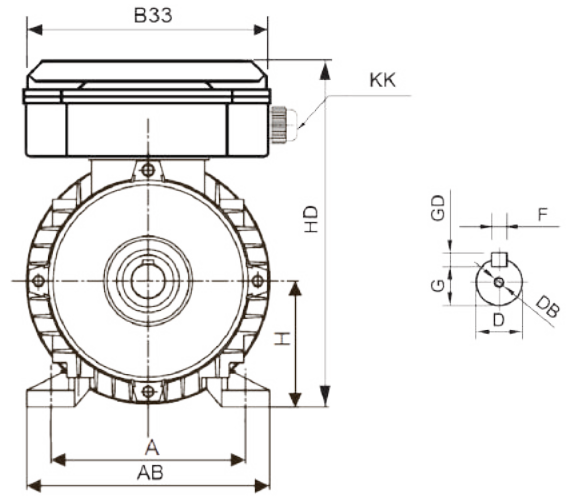
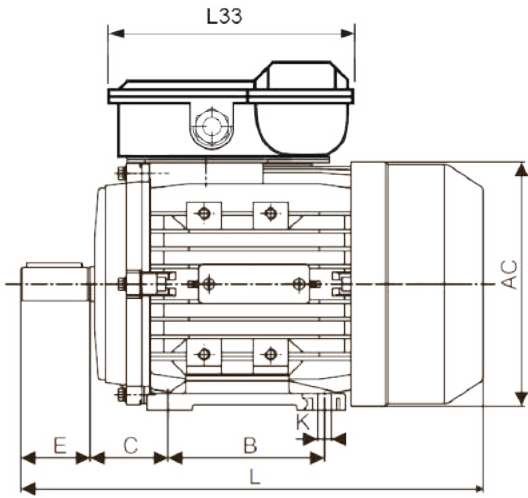

IMB5

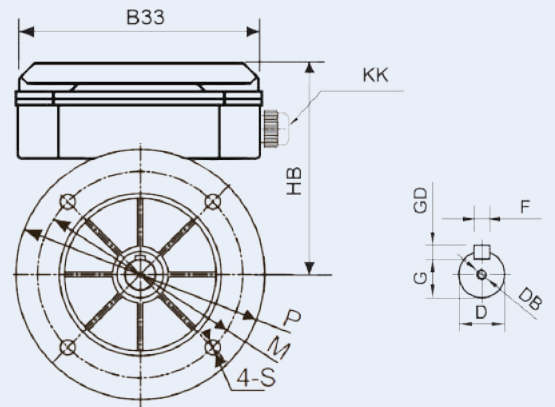
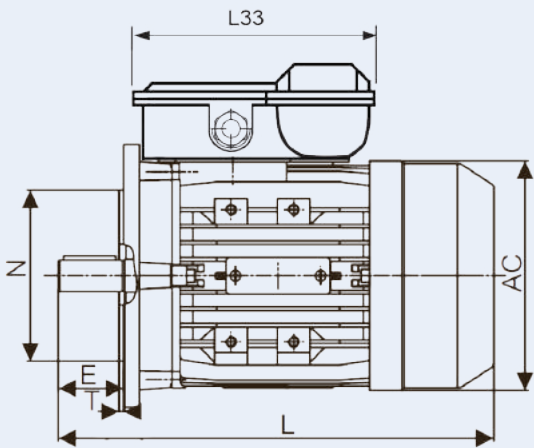

IMB14

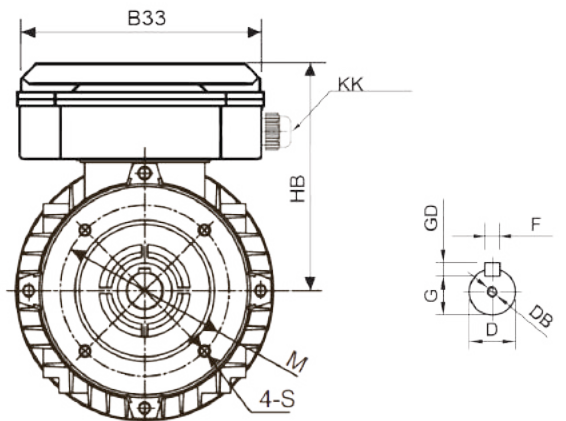
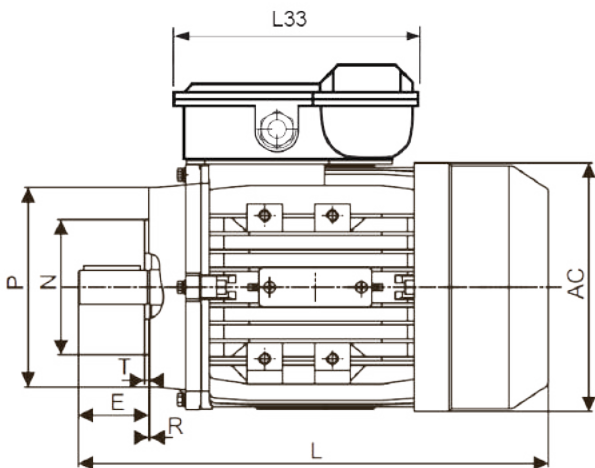

DIMENSION OF ESS



Frame size	General							Feet				
	B3, B5, B14							B3				
	AC	B33	HB	HD	KK	L	L33	A	AB	B	C	H
56	120	77	88	144	-	796	99	99	110	71	36	56
63	130	116	118	181	M20	220	92	92	120	80	40	63
71	145	116	125	196	M20	241	92	92	132	90	45	71
80	165	144	146	226	M20	290	141	141	160	100	50	80
90S	185	144	153	243	M20	312	141	141	175	100	56	90
90L	185	144	153	243	M20	337	141	141	175	125	56	90
100L	205	144	165	265	M20	369	141	141	196	140	63	100

Frame size	Shaft						Flange									
	B3, B5, B14						B5					B14				
	D	DB	E	F	G	GD	M	N	P	S	T	M	N	P	S	T
56	9	M3	20	3	7.2	3	100	80	120	7	3.0	65	50	80	M5	2.5
63	11	M4	23	4	8.5	4	115	95	140	10	3.0	75	60	90	M5	2.5
71	14	M5	30	5	11.0	5	130	110	160	10	3.5	85	70	105	M6	2.5
80	19	M6	40	6	15.5	6	165	130	200	12	3.5	100	80	120	M6	3.0
90S	24	M8	50	8	20.0	7	165	130	200	12	3.5	115	95	140	M8	3.0
90L	24	M8	50	8	20.0	7	165	130	200	12	3.5	115	95	140	M8	3.0
100L	28	M10	60	8	24.0	7	215	180	250	15	4.0	130	110	160	M8	3.5

ESD SERIES

SINGLE-PHASE CAPACITOR START AND CAPACITAL RUN ASYNCHRONOUS MOTORS ALUMINUM HOUSING



ENERTECHMOTORS.COM.AU



Performance data of ESD

Output (kW)	Frame size	Full load speed (RPM)	Current Full load I_N (A)	Efficiency at 100% full load	Power factor $\cos \phi$ at 100% full load	Locked rotor I_{st}/I_N (A)	Torque			Start Capacitor ($\mu\text{F}/\text{V}$)	Run Capacitor ($\mu\text{F}/\text{V}$)	Noise level dB (A)	Net weight (kg)
							Full load torque T_N (Nm)	Locked rotor torque T_{st}/T_N	Break down torque T_M/T_N				

3000 rpm = 2 Poles

0.18	631	2710	1.44	63	0.90	8	0.6	2.5	1.6	50 $\mu\text{F}/300\text{V}$	10 $\mu\text{F}/450\text{V}$	70	3.9
0.25	632	2710	1.97	64	0.90	10	0.9	2.5	1.6	100 $\mu\text{F}/300\text{V}$	10 $\mu\text{F}/450\text{V}$	73	4.4
0.37	711	2780	2.78	65	0.93	15	1.3	2.5	1.8	100 $\mu\text{F}/300\text{V}$	12 $\mu\text{F}/450\text{V}$	75	6.1
0.55	712	2790	3.95	68	0.93	20	1.9	2.5	1.8	100 $\mu\text{F}/300\text{V}$	16 $\mu\text{F}/450\text{V}$	76	7.0
0.75	801	2800	5.09	72	0.93	30	2.6	2.5	1.8	150 $\mu\text{F}/300\text{V}$	30 $\mu\text{F}/450\text{V}$	76	9.0
1.1	802	2810	7.36	73	0.93	40	3.7	2.5	1.8	150 $\mu\text{F}/300\text{V}$	35 $\mu\text{F}/450\text{V}$	79	10.3
1.5	90S	2810	9.91	74	0.93	55	5.1	2.5	1.8	200 $\mu\text{F}/300\text{V}$	40 $\mu\text{F}/450\text{V}$	84	16.3
2.2	90L1	2810	14.18	75	0.94	75	7.5	2.5	1.8	250 $\mu\text{F}/300\text{V}$	50 $\mu\text{F}/450\text{V}$	84	16.7
3.0	100L	2830	18.64	77	0.95	110	10.1	2.5	1.7	400 $\mu\text{F}/300\text{V}$	50 $\mu\text{F}/450\text{V}$	88	25.0
3.7	112M1	2850	22.46	78	0.96	140	12.4	2.5	1.7	600 $\mu\text{F}/300\text{V}$	60 $\mu\text{F}/450\text{V}$	90	33.0
4.0	112M2	2850	23.19	80	0.98	150	13.4	2.5	1.7	600 $\mu\text{F}/300\text{V}$	60 $\mu\text{F}/450\text{V}$	90	34.2

1500 rpm = 4 Poles

0.12	631	1350	1.10	55	0.90	6.0	0.85	2.5	1.6	30 $\mu\text{F}/300\text{V}$	10 $\mu\text{F}/450\text{V}$	64	4.1
0.18	632	1350	1.62	56	0.90	8.5	1.27	2.5	1.6	40 $\mu\text{F}/300\text{V}$	12 $\mu\text{F}/450\text{V}$	64	4.5
0.25	711	1380	2.10	60	0.90	10.0	1.73	2.5	1.7	75 $\mu\text{F}/300\text{V}$	16 $\mu\text{F}/450\text{V}$	66	5.9
0.37	712	1380	2.97	63	0.90	15.0	2.56	2.5	1.7	75 $\mu\text{F}/300\text{V}$	16 $\mu\text{F}/450\text{V}$	68	6.9
0.55	801	1400	4.21	66	0.90	20.0	3.75	2.5	1.8	100 $\mu\text{F}/300\text{V}$	20 $\mu\text{F}/450\text{V}$	71	9.6
0.75	802	1410	5.49	69	0.90	30.0	5.08	2.5	1.8	100 $\mu\text{F}/300\text{V}$	25 $\mu\text{F}/450\text{V}$	71	10.9
1.1	90S	1410	7.57	71	0.93	40.0	7.45	2.5	1.8	250 $\mu\text{F}/300\text{V}$	60 $\mu\text{F}/450\text{V}$	74	13.8
1.5	90L	1400	10.04	73	0.93	55.0	10.23	2.5	1.8	300 $\mu\text{F}/300\text{V}$	70 $\mu\text{F}/450\text{V}$	79	16.7
2.2	100L1	1430	14.53	74	0.93	75.0	14.69	2.5	1.8	300 $\mu\text{F}/300\text{V}$	70 $\mu\text{F}/450\text{V}$	79	22.8
3.0	100L2	1440	19.55	75	0.93	110.0	19.90	2.5	1.8	500 $\mu\text{F}/300\text{V}$	80 $\mu\text{F}/450\text{V}$	83	28.7
3.7	112M1	1440	22.99	77	0.95	140.0	24.54	2.5	1.7	600 $\mu\text{F}/300\text{V}$	80 $\mu\text{F}/450\text{V}$	86	31.0
4.0	112M2	1440	23.43	80	0.97	150.0	26.53	2.5	1.7	600 $\mu\text{F}/300\text{V}$	80 $\mu\text{F}/450\text{V}$	86	32.8

This data is provided for guidance only. Results are guaranteed only when confirmed by test results.

Dimension of ESD

IMB3

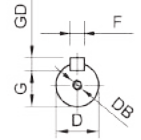
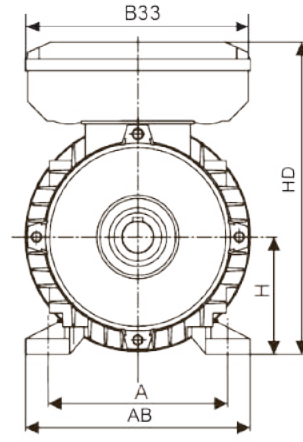
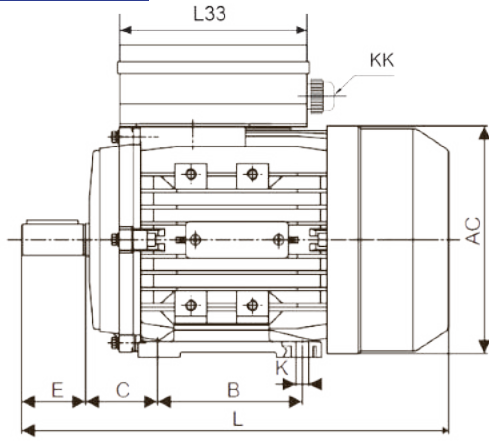

IMB5

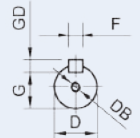
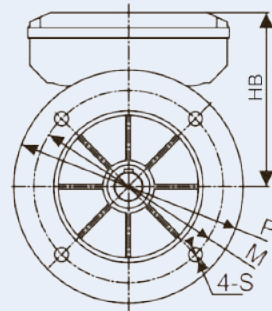
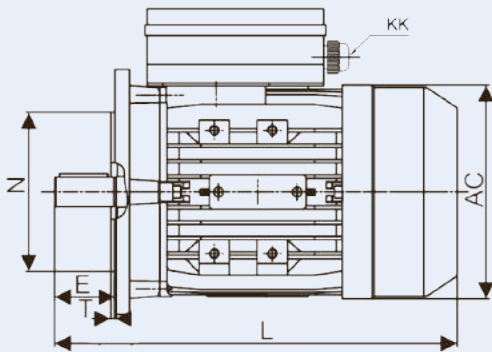

IMB14

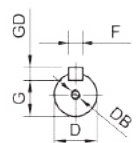
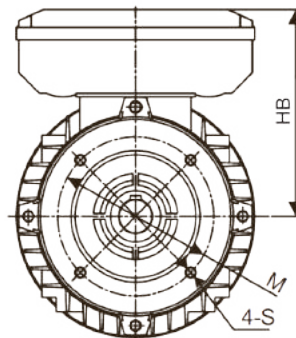
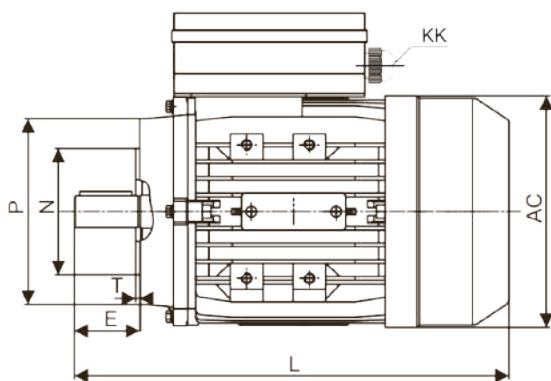

DIMENSION OF ESD



Frame size	General							Feet				
	B3, B5, B14							B3				
	AC	B33	HB	HD	KK	L	L33	A	AB	B	C	H
56	120	77	88	144	-	196	99	90	110	71	36	56
63	130	116	118	181	M20	220	92	100	120	80	40	63
71	145	116	125	196	M20	241	92	112	132	90	45	71
80	165	144	146	226	M20	290	141	125	160	100	50	80
90S	185	144	153	243	M20	312	141	140	175	100	56	90
90L	185	144	153	243	M20	337	141	140	175	125	56	90
100L	205	144	165	265	M20	369	141	160	196	140	63	100
112M	205	148	183	295	M25	416	150	190	222	140	70	112

Frame size	Shaft						Flange									
	B3, B5, B14						B5					B14				
	D	DB	E	F	G	GD	M	N	P	S	T	M	N	P	S	T
56	9	M3	20	3	7.2	3	100	80	120	7	3.0	65	50	80	M5	2.5
63	11	M4	23	4	8.5	4	115	95	140	10	3.0	75	60	90	M5	2.5
71	14	M5	30	5	11.0	5	130	110	160	10	3.5	85	70	105	M6	2.5
80	19	M6	40	6	15.5	6	165	130	200	12	3.5	100	80	120	M6	3.0
90S	24	M8	50	8	20.0	7	165	130	200	12	3.5	115	95	140	M8	3.0
90L	24	M8	50	8	20.0	7	165	130	200	12	3.5	115	95	140	M8	3.0
100L	28	M10	60	8	24.0	7	215	180	250	15	4.0	130	110	160	M8	3.5
112M	28	M10	60	8	24.0	7	215	180	250	15	4.0	130	110	160	M8	3.5

Bearing and oil seal

Aluminum Housing Electric Motors Bearings & Oil Seals

Frame	Bearings		Oil Seals	
	Drive End	Non-drive End	Drive End	Non-drive End
56	6201 ZZ C3	6201 ZZ C3	12x22x5	12x22x5
63	6201 ZZ C3	6201 ZZ C3	12x24x5	12x24x5
71	6202 ZZ C3	6202 ZZ C3	15x25x7	15x25x7
80	6204 ZZ C3	6204 ZZ C3	20x34x7	20x34x7
90S	6205 ZZ C3	6205 ZZ C3	25x37x7	25x37x7
90L	6205 ZZ C3	6205 ZZ C3	25x37x7	25x37x7
100L	6206 ZZ C3	6206 ZZ C3	30x44x7	30x44x7
112M	6306 ZZ C3	6306 ZZ C3	30x44x7	30x44x7
132S	6308 ZZ C3	6308 ZZ C3	40x58x7	40x58x7
132M	6308 ZZ C3	6308 ZZ C3	40x58x7	40x58x7
132L	6308 ZZ C3	6308 ZZ C3	40x58x7	40x58x7
160M	6309 C3	6309 C3	45x65x8	45x65x8
160L	6309 C3	6309 C3	45x65x8	45x65x8
180L	6311 C3	6311 C3	55x72x8	55x72x8

Other standards are also available on request.

Motor Spare Part List "Exploded Drawing"

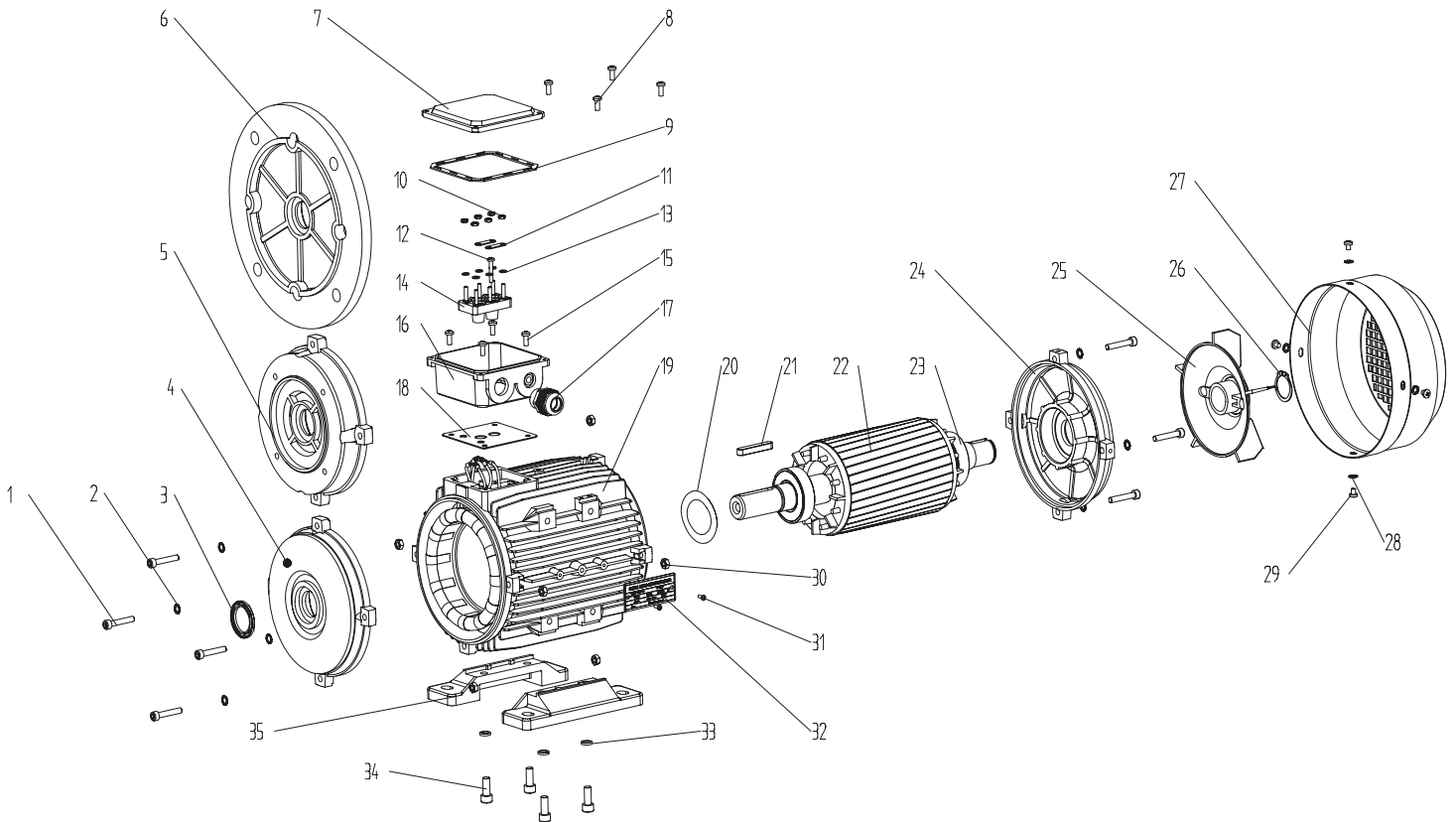

- 1. Screw
- 2. Gasket
- 3. Oil seal
- 4. Front endshield
- 5. B14 flange
- 6. B5 flange
- 7. TB cover
- 8. TB fixing screws
- 9. TB upper gasket
- 10. Terminal board fixing nut

- 11. Terminal bridge
- 12. Terminal pin
- 13. Terminal shim
- 14. Terminal board
- 15. TB fixing screws
- 16. TB base
- 17. Cable gland
- 18. TB bottom gasket
- 19. Frame
- 20. Preload washer

- 21. Key
- 22. Rotor
- 23. Bearing
- 24. NDE endshield
- 25. Cooling fan
- 26. Fan circlip
- 27. Fan cover
- 28. Fan cover fixing shim
- 29. Fan cover fixing screws
- 30. Endshield fixing nut

- 30. Endshield fixing nut
- 31. Rivet
- 32. Nameplate
- 33. Foot fixing nut
- 34. Foot fixing screws
- 35. Foot



OUR PRODUCTS



Aluminium
THREE PHASE MOTOR



Cast iron
MOTOR



Aluminium
IQF MOTOR



Cast iron
SMOKE PILL MOTOR



Aluminium
SINGLE PHASE MOTOR



Stainless steel
IQF MOTOR



Cast iron
COOLING TOWER MOTOR



Stainless steel
MOTOR

EDITION 23.01

* EnerTech Electric Motors (Australia) reserves right to make changes to this brochure without notice.



ENERTECH ELECTRIC MOTORS (AUSTRALIA)

 45 Merri Concourse, Campbellfield, Vic 3061, AUSTRALIA

 **Tel:** +61 39333 6605 - **Fax:** +61 39333 6603

 info@enertechmotors.com.au

 www.enertechmotors.com.au